

SPECIFICATION

Device Type	Top View LED
Model	CL-SFC501DBW-10K
Customer	

- Contents -

- 1. Outline Drawing And Dimension**
- 2. Material Informations**
- 3. Feature & Applications**
- 4. Absolute Maximum Ratings**
- 5. Initial Electrical/Optical Characteristics**
- 6. Ranks**
- 7. Chromaticity Coordinates Diagram**
- 8. Characteristic Diagrams**
- 9. Reliability**
- 10. Solder Conditions**
- 11. Taping**
- 12. Packing Structure**
- 13. Label Structure**
- 14. Precaution For Use**

Supplier		Customer
Written by	Approved by	Approved by

1. Outline Drawing And Dimension

(unit : mm, Tolerance : ± 0.1 mm)

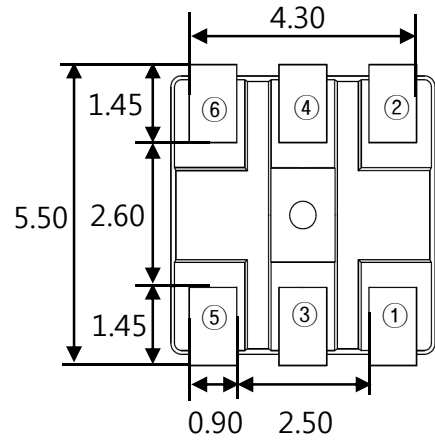
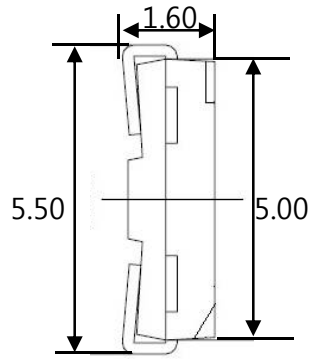
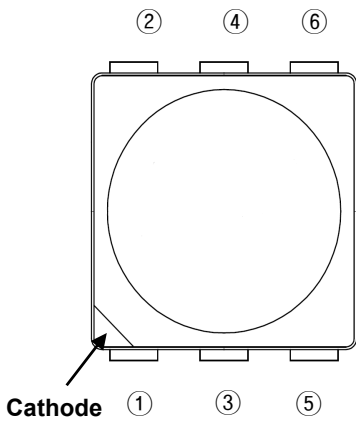

Recommended Soldering Pad Design

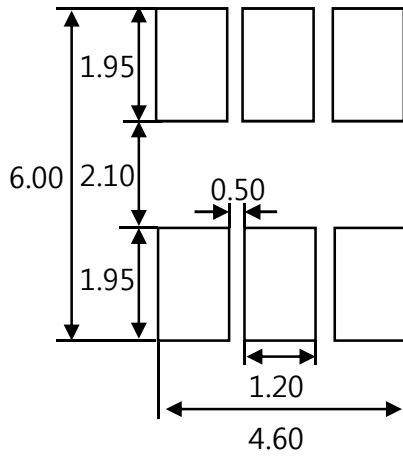

Circuit Diagram

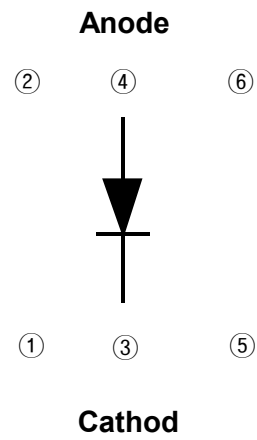

2. Material Informations

Item	Material
Chip	InGaN
Wire	Gold Wire (Au 99.99%)
LeadFrame	Copper Frame (Silver Plated)
Encapsulating Resin	Silicone + Phosphor
PPA Cup	Heat -Resistant Polymer

3. Feature & Applications

◆ Feature

- Package : SMD Top View Type
- 5.0 × 5.0 × 1.6 (L × W × H) Small Size Device
- Viewing Angle : $2\theta_{1/2} = 120^\circ$
- Colorless And Transparent Product
- InGaN Chip
- Long Time Reliability

◆ Applications

- Advertising / Corporate Identity / Sinage Back Light
- Architectural Lighting Source
- Outdoor Lighting Source

4. Absolute Maximum Ratings

(Ta = 25°C)

Items	Symbol	Absolute Maximum Ratings	Unit
Power Dissipation	P _D	260	mW
Forward Current	I _F	80	mA
Pulse Forward Current	I _{FP} * 1	160	mA
Operating Temperature	T _{opr}	-30 ~ +85	°C
Storage Temperature	T _{stg}	-40 ~ +100	°C
Soldering Temperature	T _{sld}	Reflow Soldering : 260 °C for 10sec.	
		Hand Soldering : 350 °C for 3sec.	

* 1 I_{FP} Conditions : Pulse Width ≤ 10msec. And Duty ≤ 1/10

5. Initial Electrical/Optical Characteristics

(Ta = 25°C)

Item	Symbol	Condition	Min.	Typ.	Max.	Unit
Forward Voltage	V _F	I _F = 60mA	3	-	3.5	V
Luminous Intensity * 1	I _v	I _F = 60mA	5000	-	7000	mcd
Reverse Voltage	I _R	V _R = 5V	-	-	10	μA
Viewing Angle * 3	2θ _{1/2}	I _F = 60mA	-	120	-	deg.

* 1 Luminous intensity measurement allowance is ± 10%.

* 3 θ_{1/2} : The off-axis where the luminous intensity is 1/2 of the peak intensity

Note : All measurements were made under standardized environment of CL

6. Ranks

1) Chromaticity Coordinates Rank

(Ta = 25°C)

Rank A					Test Condition I _F =60mA
X	0.283	0.283	0.293	0.293	
Y	0.269	0.297	0.319	0.291	
Rank B					
X	0.283	0.283	0.274	0.274	
Y	0.297	0.269	0.249	0.277	

※ The CIE(1931) standard colorimetric system.

※ Measurement uncertainty of the color coordinates : ± 0.01

2) Forward Voltage Rank

(Ta = 25°C)

Rank	Test Condition	Min.	Typ.	Max.	Unit
0	I _F = 60mA	3.0	-	3.1	V
1	I _F = 60mA	3.1	-	3.2	
2	I _F = 60mA	3.2	-	3.3	
3	I _F = 60mA	3.3	-	3.4	
4	I _F = 60mA	3.4	-	3.5	

※ 0.05V tolerance for the forward voltage may be caused by measurement inaccuracy.

3) Luminous Intensity Rank

(Ta = 25°C)

Rank	Test Condition	Min.	Typ.	Max.	Unit
A	I _F = 60mA	5,000	-	6,000	mcd
B	I _F = 60mA	6,000	-	7,000	

※ Luminous intensity measurement allowance is ± 10%

7. Chromaticity Coordinates Diagram

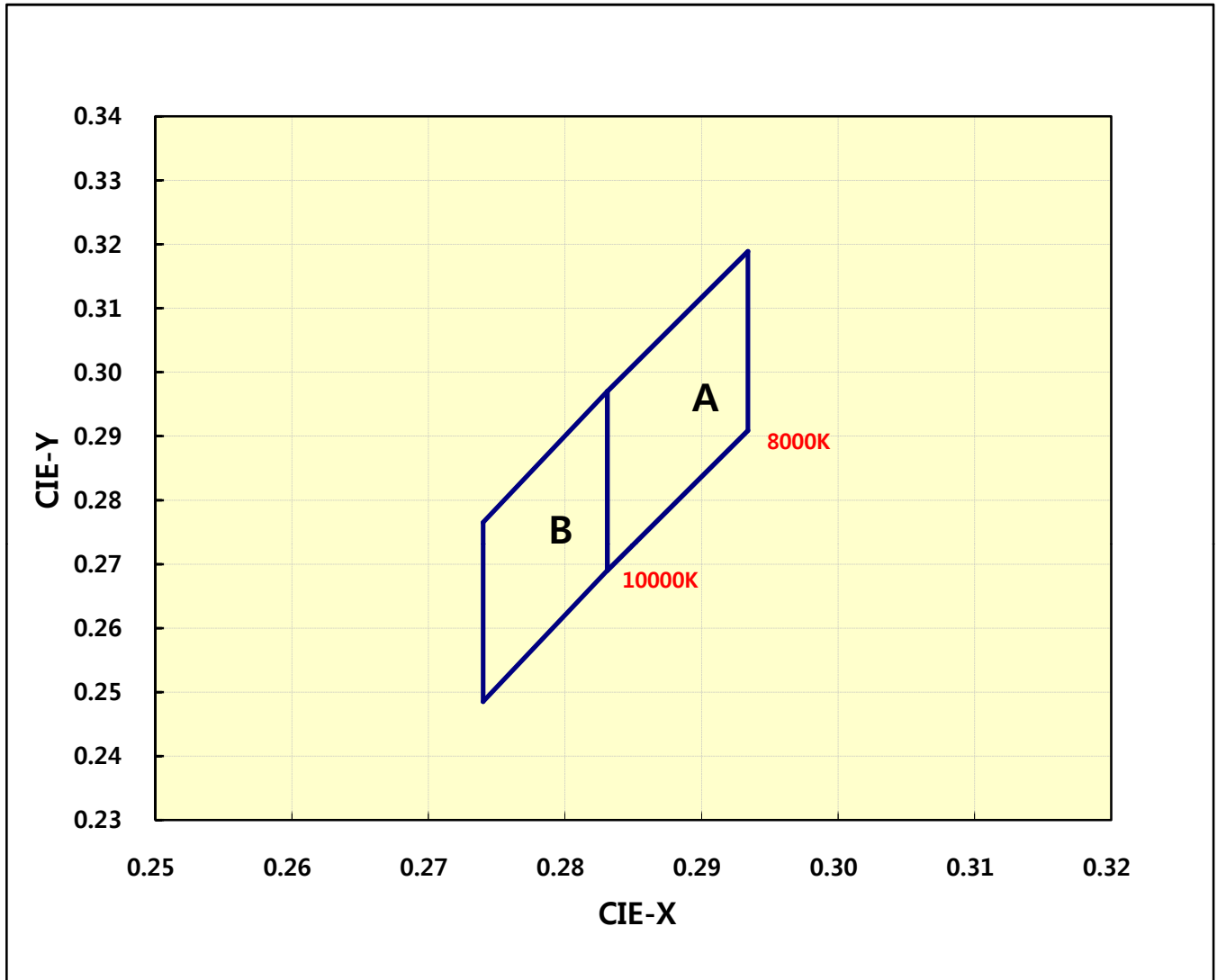

8. Characteristic Diagrams

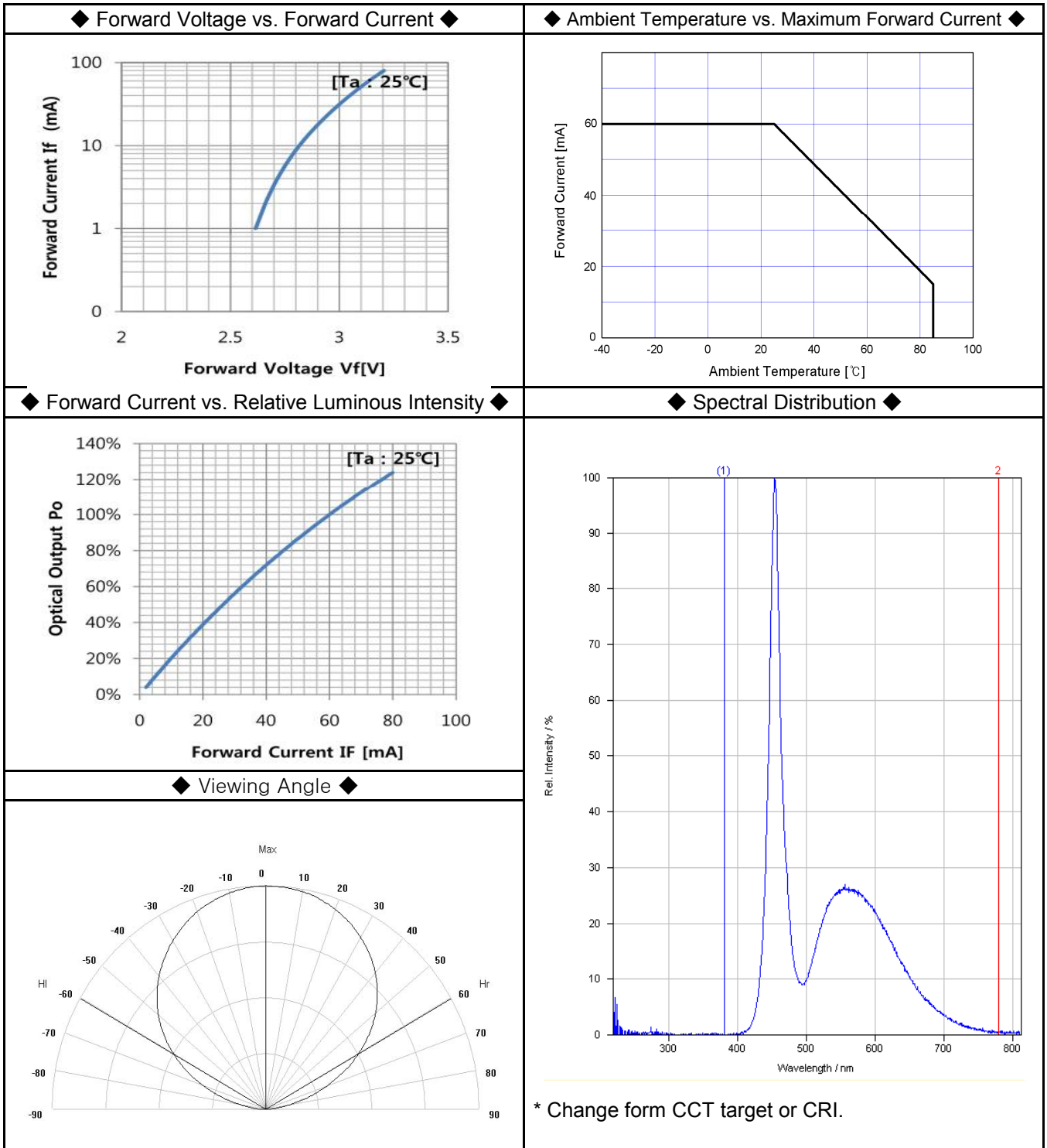

* Change form CCT target or CRI.

(Note) The Values are based on chip performance.

9. Reliability

1) Test Items and Results

Test Item	Test Conditions	Note (Hours/Cycles)	Number of Damaged
High Temperature Storage	Ta = 100°C	1000 Hours	0/22
Low Temperature Storage	Ta = -40°C	1000 Hours	0/22
High Temperature High Humidity Storage	Ta = 60°C, RH = 90%	1000 Hours	0/22
Temperature Cycle	-40°C ~ 25°C ~ 100°C ~ 25°C 30min 5min 30min 5min	100 Cycles	0/22
Resistance to Soldering Heat (Reflow Soldering)	Tsld = 260°C, 10sec (Pre Treatment 30°C, 70%, 168Hrs)	2 times	0/22
Solderability (Reflow Soldering)	Tsld = 215±5°C, 3sec (Using Flux, Lead Solder)	1 time (over 95%)	0/22
* ³ Room Temperature Life Test	25°C, I _F = 60mA	1000 Hours	0/22
* ³ High Temperature Life Test	Ta = 85°C, I _F = 15mA	1000 Hours	0/22
* ³ High Temperature High Humidity Life Test	Ta = 60°C, RH = 90%, I _F = 36mA	1000 Hours	0/22
* ³ Low Temperature Life Test	Ta = -30°C, I _F = 60mA	1000 Hours	0/22

2) Criteria for Judging the Damage

Item	Symbol	Test Condition	Limit	
			Min.	Max.
Forward Voltage	V _F	I _F = 60mA	-	* ¹ U.S.L × 1.1
Luminous Intensity (1)	I _v	I _F = 60mA	* ² L.S.L × 0.7	-
Luminous Intensity (2)	I _v	I _F = 60mA	* ² L.S.L × 0.5	-

*¹ U.S.L = Upper Standard Level

*² L.S.L = Lower Standard Level

*³ These test items are judged by the criteria of Luminous Intensity (2).

10. Solder Conditions

1) Reflow Conditions (Lead Solder)

- Preliminary heat to be at Max. 200°C for Max. 2 mins.
- Soldering heat to be at Max. 240°C for Max. 10 secs.

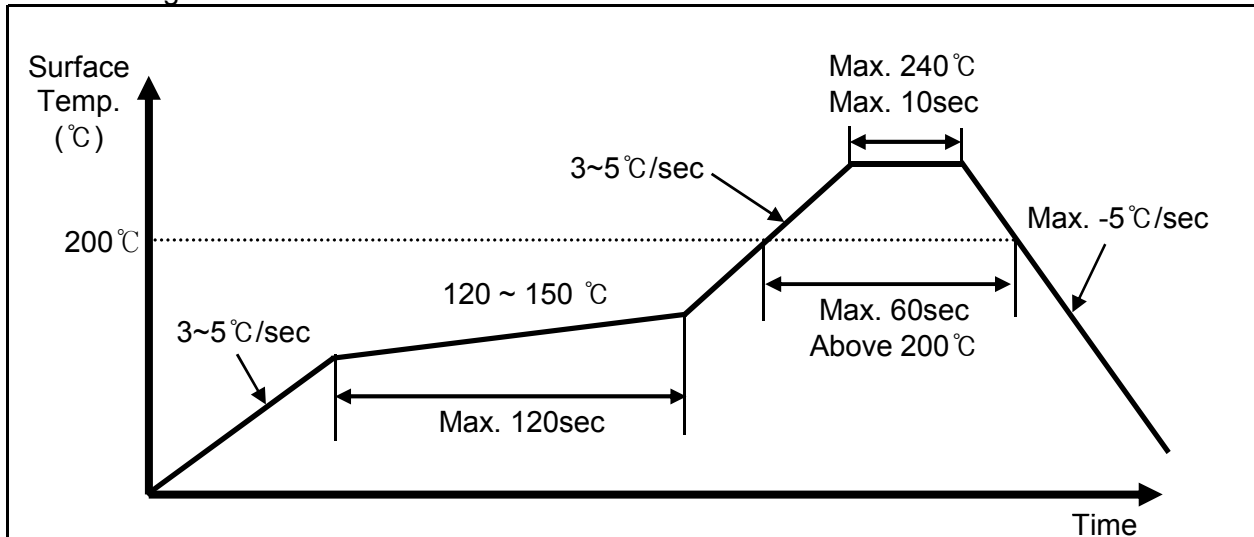

2) Reflow Conditions (Pb Free)

- Preliminary heat to be at Max. 220°C for Max. 2 mins.
- Soldering heat to be at Max. 260°C for Max. 10 secs.
- Reflow frequency : 2 times max.

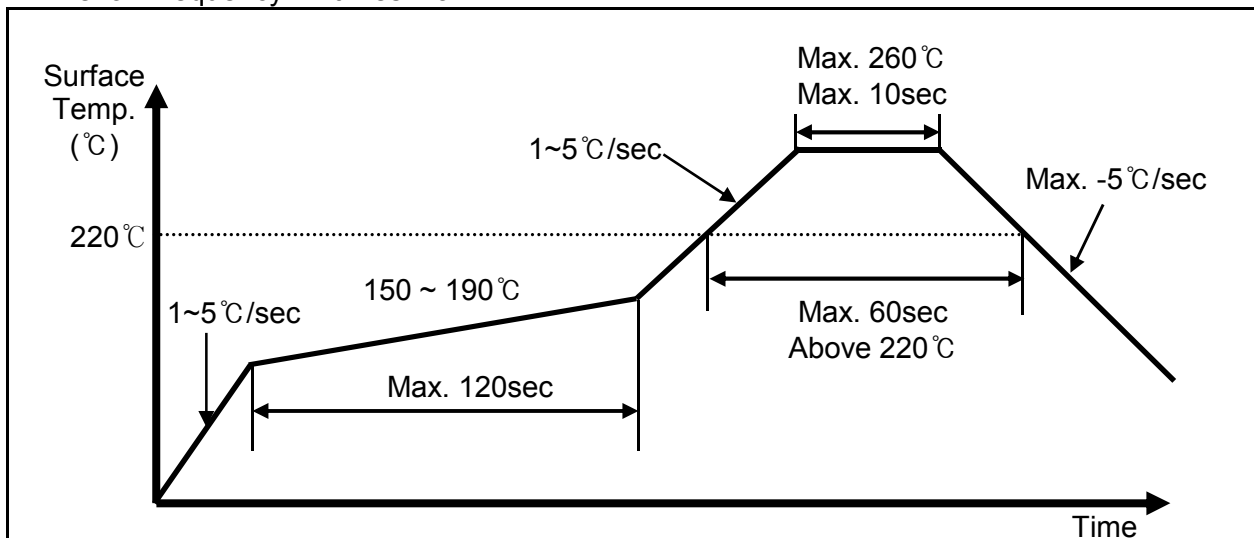

3) Hand Soldering Conditions

- Not more than 3 seconds at 350°C, under soldering iron. (One time Only)

11. Taping

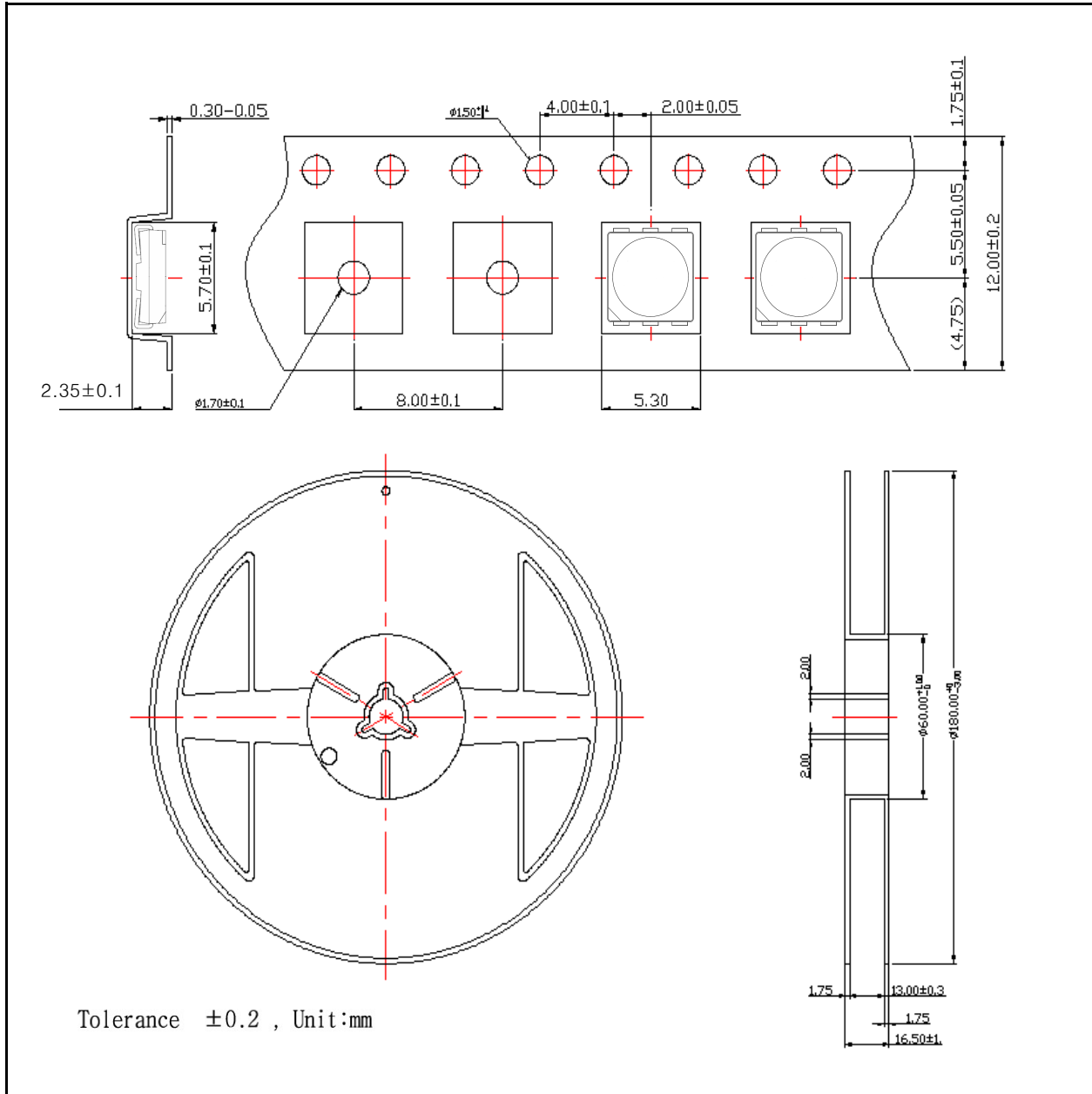

- 1) Quantity : The quantity/Reel to be 1,000pcs.
- 2) Cumulative Tolerance : Cumulative Tolerance/10 pitches to be ± 0.2 mm
- 3) Adhesion Strength of Cover Tape : Adhesion strength to be 0.1~0.7N when the cover tape is turned off from the carrier tape at 10° angle to be the carrier tape.
- 4) Packing : P/N, Manufacturing data Code No. and quantity to be indicated on a damp proof package.

12. Packing Structure

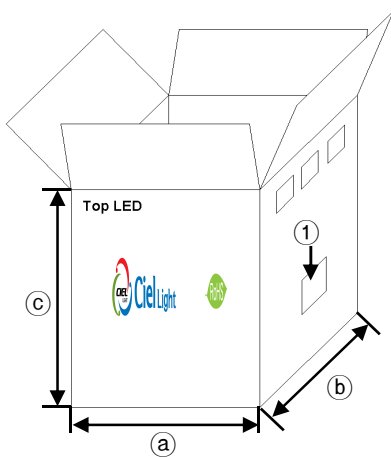
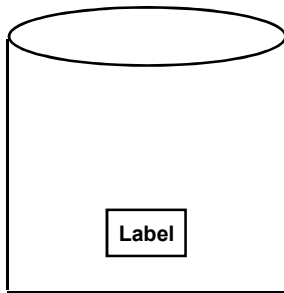
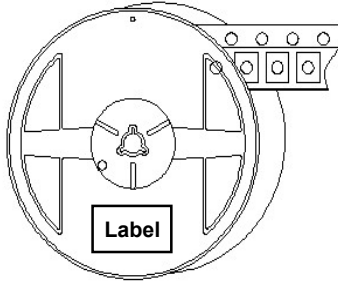

Inner Box (Max. 10Reels)

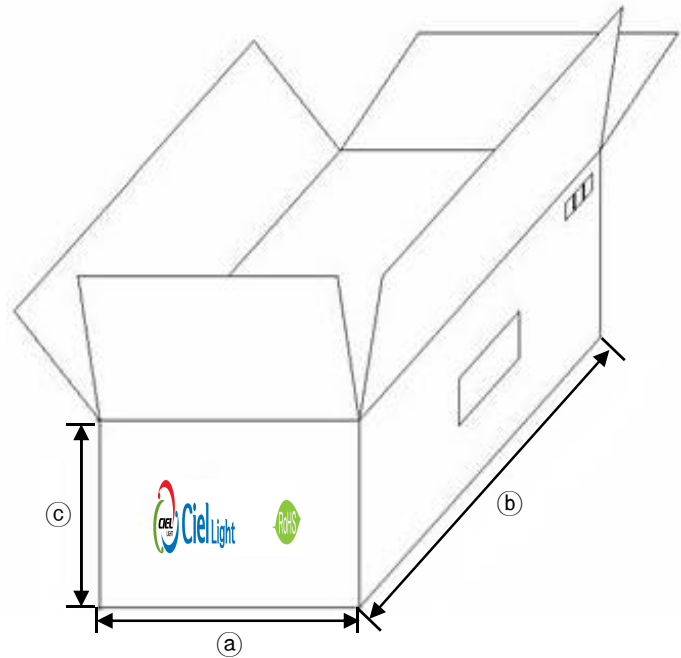

Outer Box (Max. 8 Inner Boxes)

① Label Outlines (70 x 45 mm)



Box Structure Material : Paper (SW3B(B))

Type	Size(mm)		
	(a)	(b)	(c)
Inner	220	160	260
Oute	465	610	300

13. Label Structure

Rank & P/N(Product Number) is composed of the following characters:

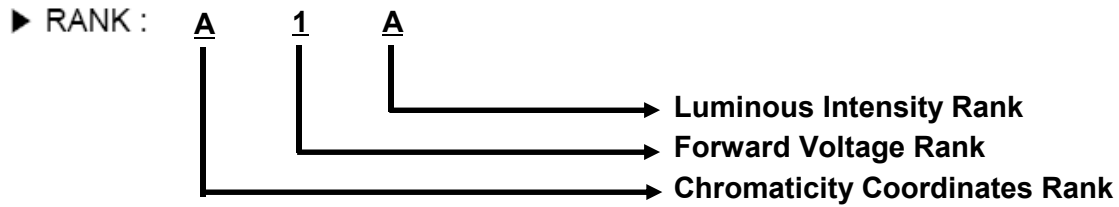

14. Precaution For Use

1) Storage

In order to avoid the absorption of moisture, it is recommended to store in a dry box (or a desiccator) with a desiccant. Otherwise, to store them in the following environment is recommended.

Temperature : 5 °C ~ 30 °C Humidity : maxim 65%RH

2) Attention after open.

LED is correspond to SMD, when LED be soldered dip, interfacial separation may affect the light transmission efficiency, causing the light intensity to drop. Attention in followed;

a. After opened and mounted the soldering shall be quickly.

b. Keeping of a fraction

Temperature : 5 ~ 40 °C Humidity : less than 30%

3) It is recommended that user should complete the use of the whole package within 48 hours upon unsealing. In the event of incomplete usage, It is advised that user preheat the remaining devices at 60±5 °C for 10-12hours prior to use.

4) Any mechanical force or any excess vibration shall not be accepted to apply during cooling process to normal temperature after soldering.

5) Quick cooling shall be avoided.

6) Components shall not be mounted on wrapped direction of PCB.

7) Anti radioactive ray design is not considered for the products.

8) This device should not be used in any type of fluid such as water, oil, organic solvent, etc.
When washing is required, IPA should be used.

9) When the LEDs are illuminating, operating current should be decided after considering the ambient maximum temperature.

10) LEDs must be stored to maintain a clean atmosphere.

If the LEDs are stored for 3months or more after being shipped from CL, a sealed container with a nitrogen atmosphere should be used for storage.

11) The LEDs must be used within one day after opening the moisture proof packing. Repack unused products with anti-moisture packing, fold to close any opening and then store in a dry place

12) Repack unused products with one day after opening the moisture-proof packing.

13) The appearance and specifications of the product may be modified for improvement without notice.