

## Data Sheet

---

Customer: \_\_\_\_\_  
Part No: \_\_\_\_\_ CL-SF681IR-940 \_\_\_\_\_  
Sample No: \_\_\_\_\_  
Description: \_\_\_\_\_ 3528 IR SMD \_\_\_\_\_  
Item No: \_\_\_\_\_

Customer			
Check	Inspection	Approval	Date

## CL-SF681IR-940

### Features:

- . Reflow Solderable
- . High Luminous Intensity and Low Power Dissipation
- . Good Reliability and Long Life
- . Complied With RoHS Directive

### Technical Data Sheet

This product is generally used as indicator and luminary for electronic equipment such as household appliance, communication equipment, and dashboard.

### Applications

- Applicable to all kinds of mechanical keyboard launch requirements
- Suitable for all kinds of infrared transmitting and receiving equipment
- Infrared remote control transmitter is suitable for all kinds of electronic products
- Applicable to all kinds of small household electrical appliance products for reflectic

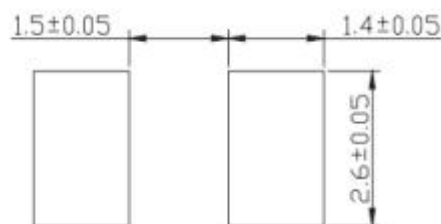
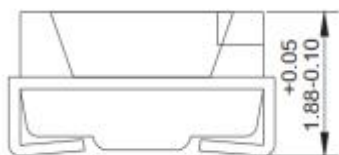
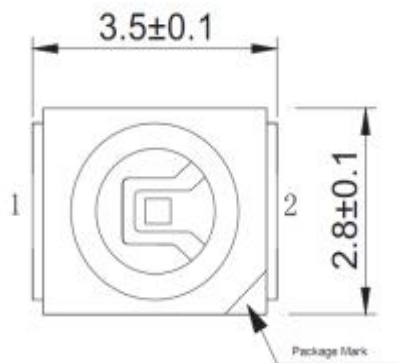
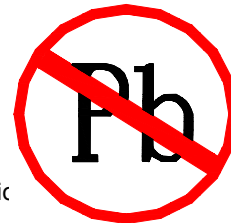

#### Notes:

1. All dimension units are millimeters.
2. All dimension tolerance is  $\pm 0.2$ mm unless otherwise noted.

**CL-SF681IR-940**
**Electrical / Optical Characteristics at Ta=25°C**

Parameter	Test Condition	Symbol	Value			Unit
			Min.	Typ.	Max.	
Forward voltage	If=20mA	VF	--	1.22	1.50	V
Emission intensity	If=20mA	Ee	--	20.00	40.00	mW\sr
Firing angle	If=20mA	2 θ 1/2	--	120.00	--	Deg
Wavelength	If=20mA	λP	--	940.00	--	nm

Note:

- 1.2θ1/2 is the angle from optical centerline where the luminous intensity is 2θ1/2 the optical centerline value.
- 2.the above luminous intensity measurement allowance tolerance ±10%

**Absolute Maximum Ratings at Ta=25°C**

Parameter	Symbol	Value	Unit
Power dissipation	Pd	60	mW
Forward current	If	20	mA
Reverse voltage	Vr	5	V
Operating temperature range	Top	-30 ~+85	°C
Storage temperature range	Tstg	-40~+100	°C
Peak pulsing current	Ifp	100	mA
Electrostatic Discharge	ESD	2000(HBM)	V

Note:

1. 1/10 Dut cycle,0.1ms pulse width.

## CL-SF681IR-940

### Typical optical characteristics curves

Ambient Temperature VS. Forward Current

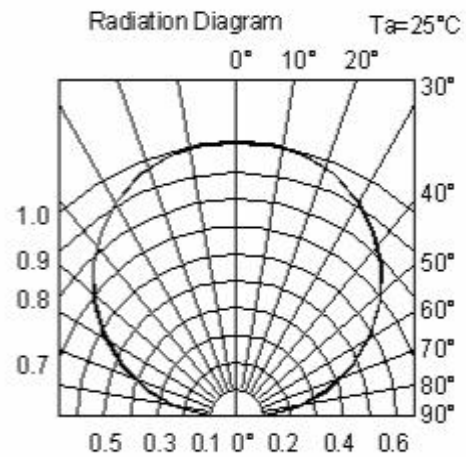
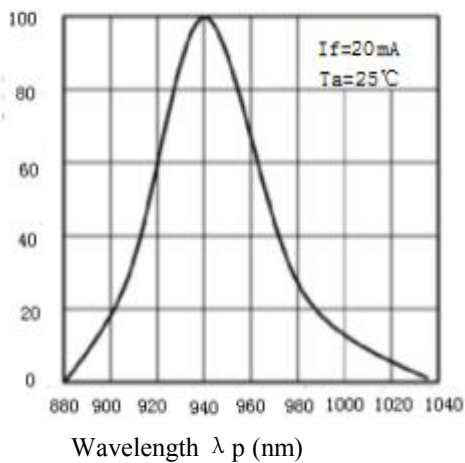
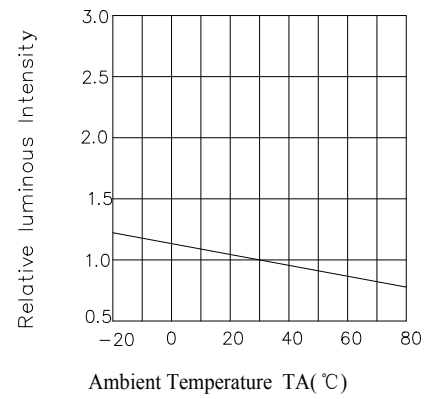
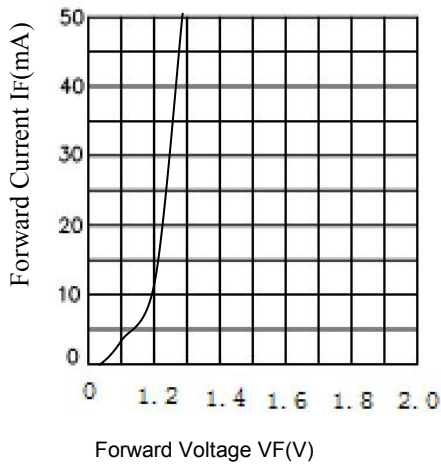
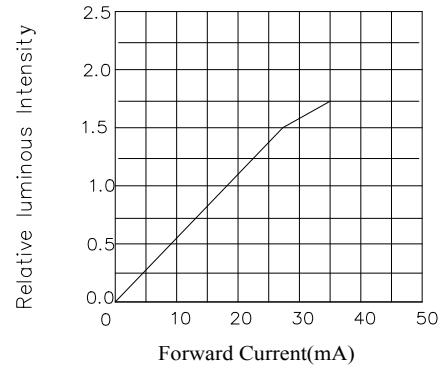
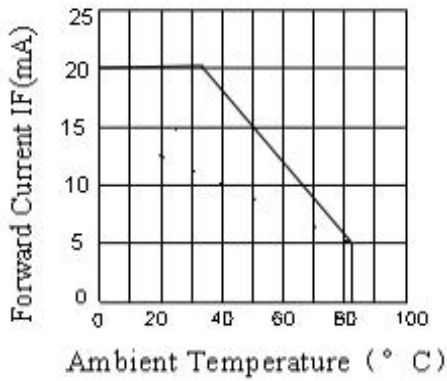

**Reliability Test Items And Conditions**

The reliability of products shall be satisfied with items listed below.

Confidence level :90%

LTPD :10%

Test Items	Test conditions	Quantity	Judging Criteria
Solderability	Solder Temperature: 240°C Solder Duration: (3.5±0.5) sec.	22	Solderable Area Over 95%
Thermal Shock Followed by High Temperature And High Humidity Cyclic	-40° → 10min 5 Cycles ↑ ↓ shift(2~3)min 100°C → 10 min. ☰ 25°C~55°C (90%~95%) RH 2 Cycles for 48 hrs., Recover for 2 hrs	22	C=0 & I**
Resistance For Soldering Heat	Reflow Soldering	22	C=0 & I**
DC Operating Life	1000 hrs. Forward Current: 70mA	22	C=0 & I**
High Temperature Storage	100°C ☐ → 1000 hrs	22	C=0 & I**
High Temperature And High Humidity Cyclic	25°C~55°C (90%~95%) RH 6 Cycles for 144 hrs., Recover for 2 hrs.	22	C=0 & I**

The technical information shown in the data sheets are limited to the typical characteristics and circuit examples of the referenced products. It does not constitute the warranting of industrial property nor the granting of any license.

## CL-SF681IR-940

### SMT Reflow Soldering Instructions

- 1.Reflow soldering is not can do two times
- 2.When soldering , do not put stress on the LEDs during heating .

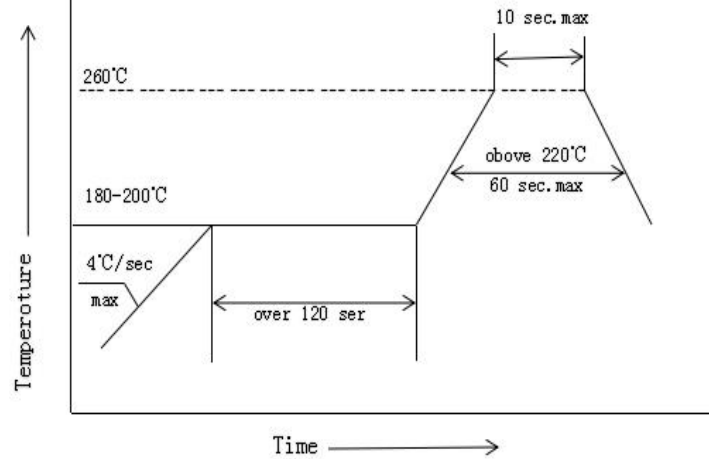

### Soldering iron

- 1.When hand soldering, the temperature of the iron must less than 300°C for 3 seconds
- 2.The hand solder should be done only one times

### Repairing

Repair should not be done after the LEDs have been soldered. When repairing is unavoidable, a double-head soldering iron should be used (as below figure). It should be confirmed beforehand whether the characteristics of LEDs will or will not be damaged by repairing.

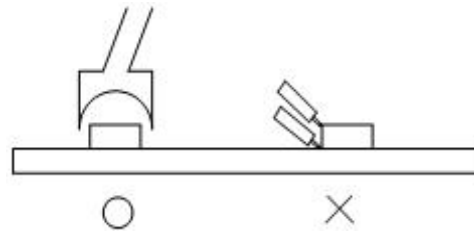

### Cautions

The encapsulated material of the LEDs is silicone. Therefore the LEDs have a soft surface on the top of package. The pressure to the top surface will be influence to the reliability of the LEDs. Precautions should be taken to avoid the strong pressure on the encapsulated part. So when use the picking up nozzle,the pressure on the silicone resin should be proper.

### Handling Precautions

- 1.Do not stack together assembled PCBs containing LEDs. Impact may scratch the silicone lens or damage.

- 2.Not available in the situation of acidity for PH.

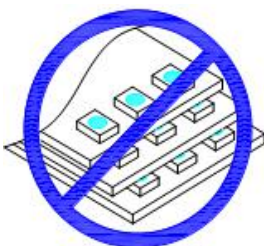

## CL-SF681IR-940

### Carrier tape

Carrier tape (MPQ:2000PCS/reel)

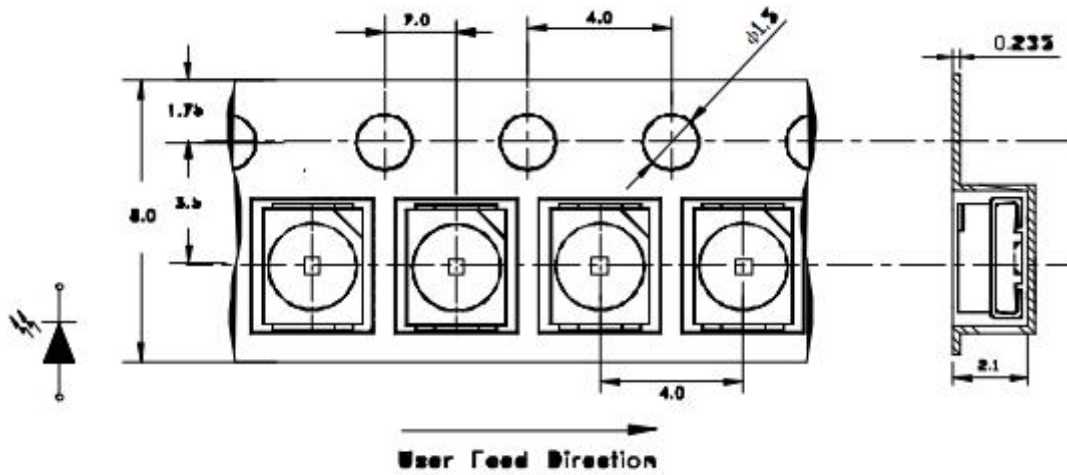

Note: The tolerances unless mentioned is  $\pm 0.1$  mm, Unit: mm

### Moisture Resistant Packaging

