



# Data Sheet

---

Customer:

Part No: CL-SF681UV-370

Sample No:

Description: 3528 UV SMD

Item No: \_\_\_\_\_

Customer			
Check	Inspection	Approval	Date

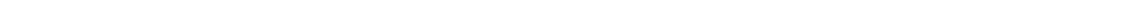

### Features:

- . Reflow Solderable
- . High Luminous Intensity and Low Power Dissipation
- . Good Reliability and Long Life
- . Complied With RoHS Directive

### Technical Data Sheet

This product is generally used as indicator and luminary for electronic equipment such as household appliance, communication equipment, and dashboard.

### Applications

- Optical indicator
- Indoor display
- Backlighting in dashboard and switch
- Flat backlighting for LCD, symbol and display
- General use

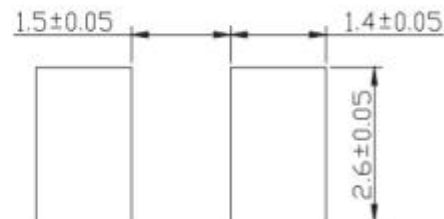
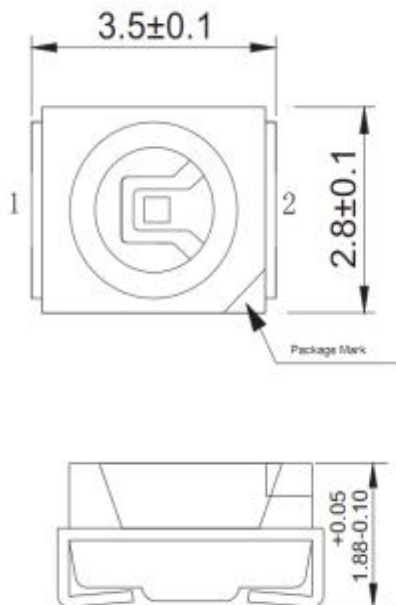

#### Notes:

1. All dimension units are millimeters.
2. All dimension tolerance is  $\pm 0.2$ mm unless otherwise noted.

## CL-SF681UV-370

### Selection Guide

Part No.	Chip Materials	Lens Type	Luminous intensity(mcd) @ 20mA			Viewing Angle
			Min	Typ	Max	2θ1/2
CL-SF681UV-370	Purple (InGaN )	Water Clear	10	--	35	120

Note:

- 1.2θ1/2 is the angle from optical centerline where the luminous intensity is .2θ1/2 the optical centerline value.
- 2.The above luminous intensity measurement allowance tolerance ±10%

### Electrical / Optical Characteristics at Ta=25°C

Parameter	Symbol	Min.	Typ.	Max	Units	test conditions
Forward Voltage	VF	2.8	--	3.6	V	IF=20mA
Reverse Current	IR	--	--	10	uA	VR = 5V
Peak Wavelength	λP	370	--	380	nm	IF=20mA

### Absolute Maximum Ratings at Ta=25°C

Parameter	Symbol	Rating	Units
Power Dissipation	Pd	72	mW
DC Forward Current	IF	20	mA
Peak Forward Current [1]	IFP	100	mA
Reverse Voltage	VR	5	V
Electrostatic Discharge (HBM)	ESD	2000	V
Operating Temperature	Topr	-40~+85	°C
Storage Temperature	Tstg	-40~+100	°C

Note:

1. 1/10 Dut cycle,0.1ms pulse width.
2. The above forward voltage measurement allowance tolerance ±0.1V.
3. The tolerance of wave length:±1nm.

# CL-SF681UV-370

## Typical optical characteristics curves

Ambient Temperature VS. Forward Current

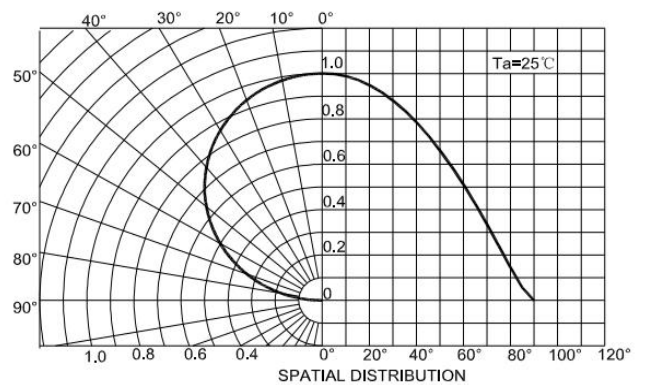
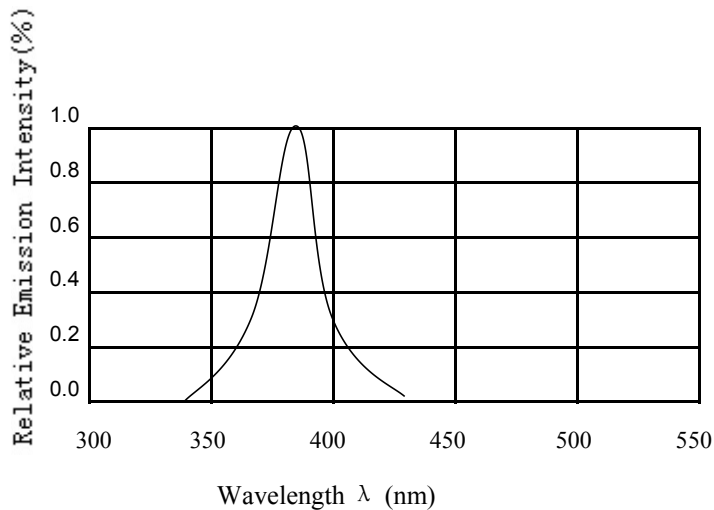
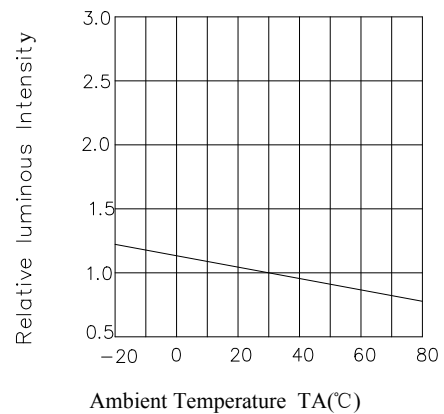
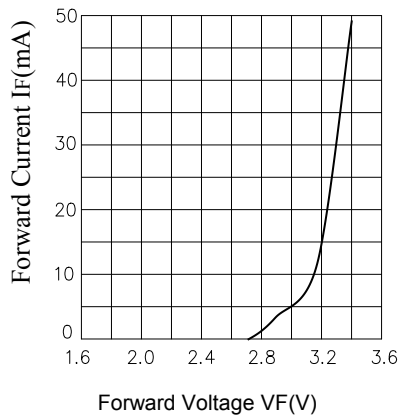
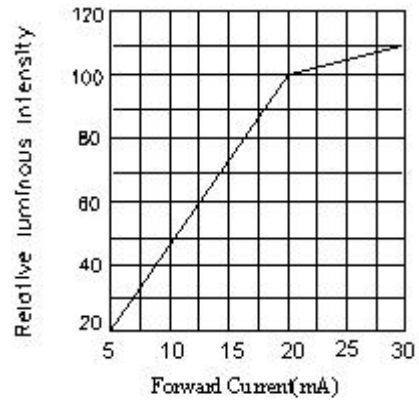
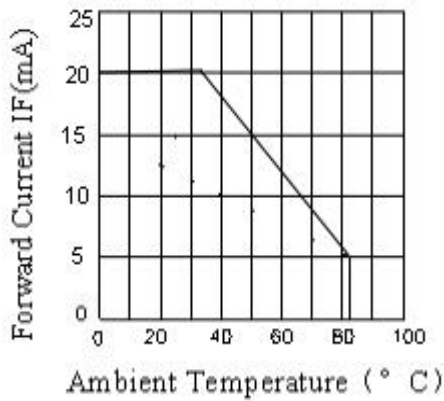

**Reliability Test Items And Conditions**

Test Items	Ref.Standard	Test conditions	Time	Quantity	Ac/Re
Reflow	JESD22-B106	Temp:260°C max T=10 sec	3 times.	22Pcs.	0/1
Temperature Cycle	JESD22-A104	-40°→30min 5 Cycles↑↓shift(5)min 100°C →30 min. 25°C~55°C	100 Cycles	22Pcs.	0/1
High Temperature Storage	JESD22-A103	Temp:100°C±5°C	1000Hrs	22Pcs.	0/1
Low Temperature Storage	JESD22-A119	Temp:-40°C±5°C	1000Hrs	22Pcs.	0/1
Life Test	JESD22-A108	Ta=25°C±5°C IF=20mA	1000Hrs	22Pcs.	0/1
High Temperature High Humidity Life Test	JESD22-A101	85°C±5°C/ 85%RH IF=20mA	1000Hrs	22Pcs.	0/1

**Criteria For Judging Damage**

Test Items	Symbol	Test conditions	Criteria For Judgement	
			Min.	Max.
Forward Voltage	VF	IF=20mA		U.S.L*)x1.1
Reverse Current	IR	VR = 5V		U.S.L*)x2.0
Luminous intensity	IV	IF=20mA	L.S.L*)x0.7	

U.S.L: Upper standard level

L.S.L: Lower standard level

The technical information shown in the data sheets are limited to the typical characteristics and circuit examples of the referenced products.It does not constitute the warranting of industrial property nor the granting of any license.

### SMT Reflow Soldering Instructions SMT

1. It is recommended that the reflow soldering should not be more than once.  
If it is subjected to two high temperature processing, please finish in 24H.
2. When soldering, do not put stress on the LEDs during heating.

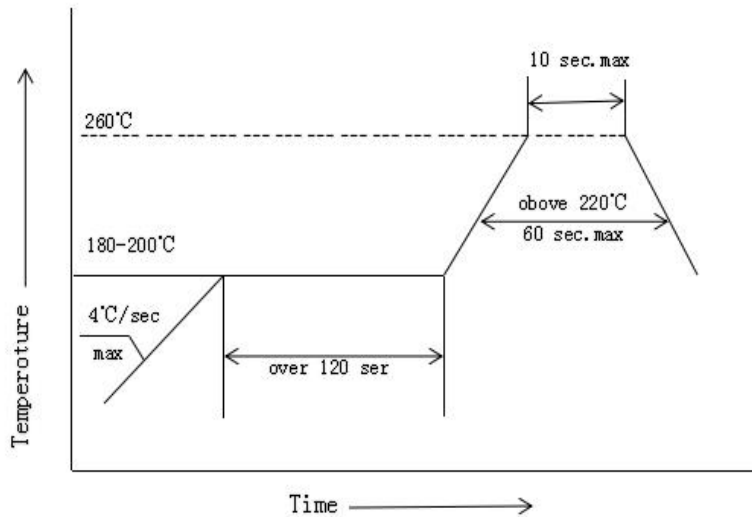

### Soldering iron

1. When hand soldering, the temperature of the iron must be less than 300°C for 3 seconds.
2. The hand solder should be done only one time.

### Repairing

Repair should not be done after the LEDs have been soldered. When repairing is unavoidable, a double-head soldering iron should be used (as shown in the figure below). It should be confirmed beforehand whether the characteristics of LEDs will or will not be damaged by repairing.

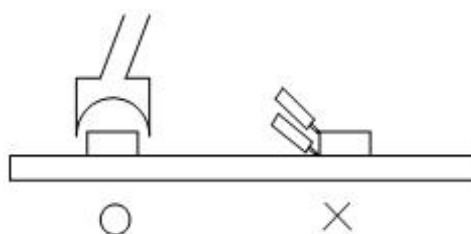

## Storage

The package is sealed:

- 1.Recommended storage condition :At 5°C~30°C and relative humidity 90% RH max.
- 2.It is recommended that SMD out of their original packaging are used within one year.

The package is opened:

- 1.Completed within 24 hours.
- 2.Stored at5°C~30°C and 60% RH or less.
- 3.LEDs stored more than 24 hours should be baked at about 65°C±5°C for at least 24 hours before solder assembly.

## ESD

Static Electricity will damage the LED.

The following procedures may decrease the possibility of ESD damage.

- 1.All productive machinery and test instruments must be electrically grounded.
- 2.Use a conductive wrist band or anti-electostatic glove when handling these LEDs.
- 3.Manintain a humidity level of 50%RH or higher in production areas.
- 4.Use anti-static packaging for transport and storage.

## Handling Precautions

- 1.Do not stack together assembled PCBs containing LEDs. Impact may scratch the silicone lens or damage.
- 2.Not available in the situation of acidity for PH.
- 3.Electrostatic sensitive device

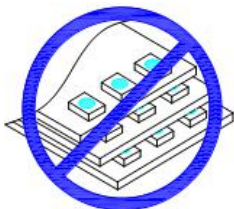

**Packaging**

Carrier tape (MPQ:2000PCS/reel)

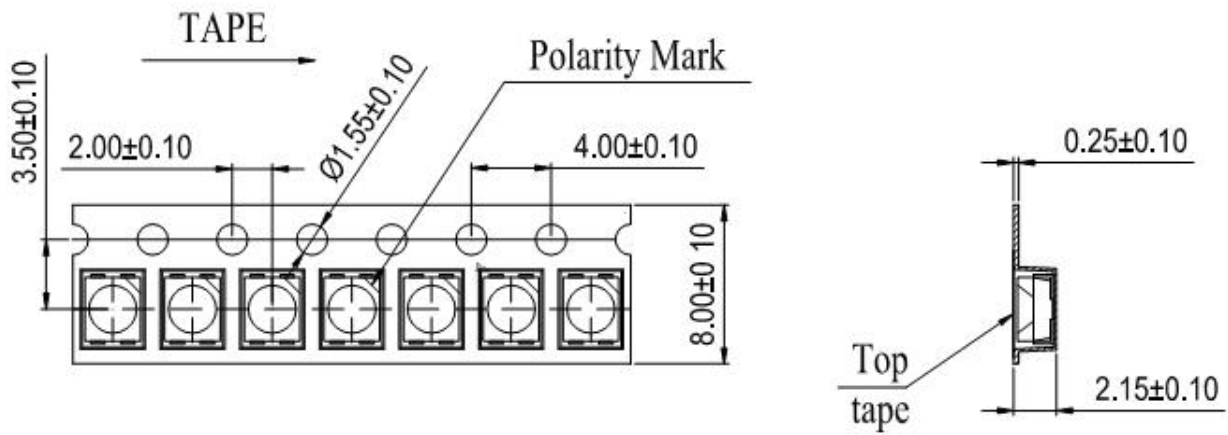
 Note: The tolerances unless mentioned is  $\pm 0.1$  mm, Unit: mm

**Moisture Resistant Packaging**
