

Data Sheet

Customer: _____
Part No: CL-SFC506DWW-3K-90CRI
Sample No: _____
Description: 5050 Warm White SMD
Item No: _____

Customer			
Check	Inspection	Approval	Date

CL-SFC506DWW-3K-90CRI

Features:

- . Reflow Solderable
- . High Luminous Intensity and Low Power Dissipation
- . Good Reliability and Long Life
- . Complied With RoHS Directive

Technical Data Sheet

This product is generally used as indicator and luminary for electronic equipment such as household appliance, communication equipment, and dashboard.

Applications

- Optical indicator
- Indoor display
- Backlighting in dashboard and switch
- Flat backlighting for LCD, symbol and display
- General use

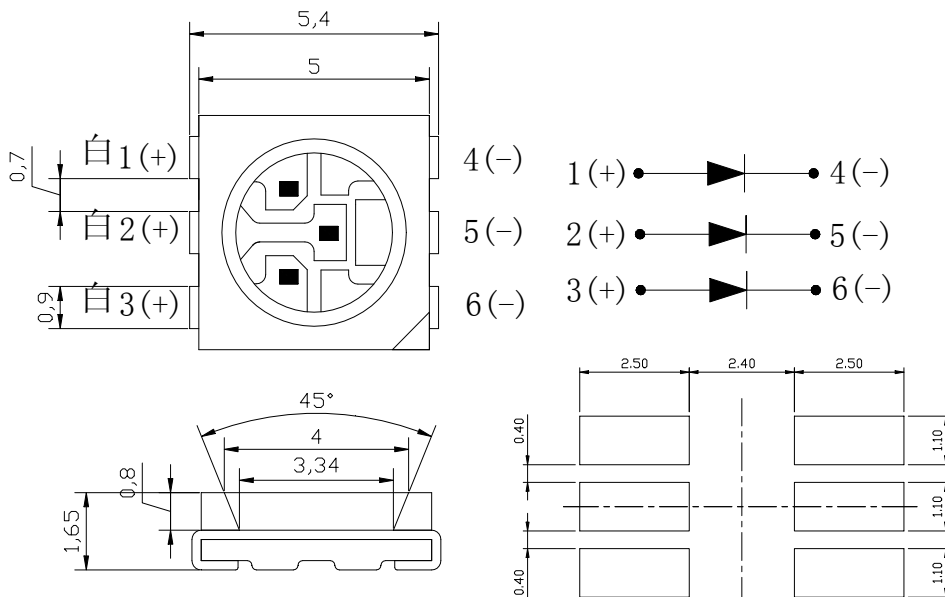

Notes:

- 1 . All dimension units are millimeters.
2. All dimension tolerance is $\pm 0.2\text{mm}$ unless otherwise noted.

CL-SFC506DWW-3K-90CRI

Selection Guide

Part No.	Dice	Lens Type	Luminous Flux(Lm) 60mA			Viewing Angle
			Min	Typ	Max	201/2
CL-SFC506DWW-3K-90CRI	Blue (InGaN)	Yellow Diffused	20	22	24	120

Note:

- 1.1/2 is the angle from optical centerline where the luminous intensity is 1/2 the optical centerline value.
- 2.the above luminous intensity measurement allowance tolerance $\pm 10\%$
- 2.30LM above Products lumens allow differences: $\pm 1LM$

Electrical / Optical Characteristics at Ta=25°C

Parameter	Symbol	Min.	Typ.	Max	Units	test conditions
Forward Voltage	VF	2.8	3.2	3.4	V	IF=60mA
Reverse Current	IR	--	--	10	uA	VR = 5V
Color Rndering Index	CRI	90	--	--		IF=60mA
Color Temperature	Tc	2800	--	3100	K	IF=60mA

Absolute Maximum Ratings at Ta=25°C

Parameter	Symbol	Rating	Units
Power Dissipation	Pd	200	mW
DC Forward Current	IF	60	mA
Peak Forward Current [1]	IFP	90	mA
Reverse Voltage	VR	5	V
Electrostatic Discharge (HBM)	ESD	2000	V
Operating Temperature	Topr	-30~+85	°C
Storage Temperature	Tstg	-40~+100	°C

Note:

1. 1/10 Dut cycle,0.1ms pulse width.
- 2.The above forward voltage measure ment allowance tolerance $\pm 0.1V$.
- 3.3000-5000K Colour temperature product Colour temperature allow differences $\pm 50K$.
- 3.Colour rendering index allow differences -1Ra.

CL-SFC506DWW-3K-90CRI

Typical optical characteristics curves

Ambient Temperature VS. Forward Current

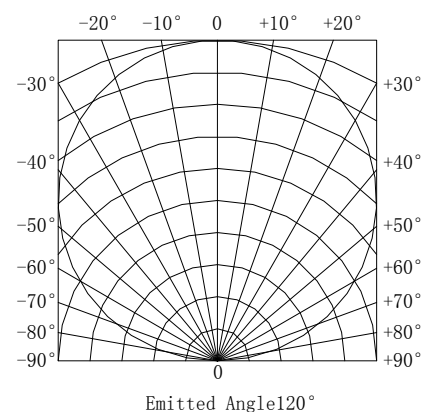
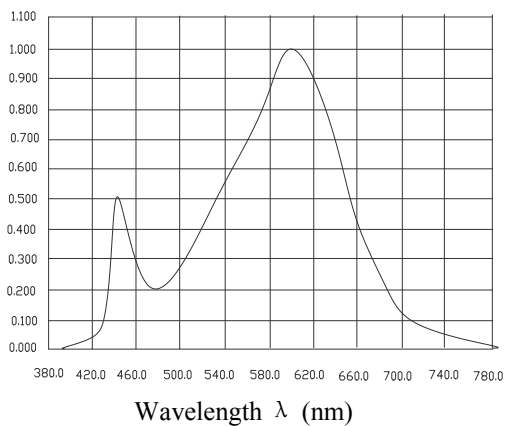
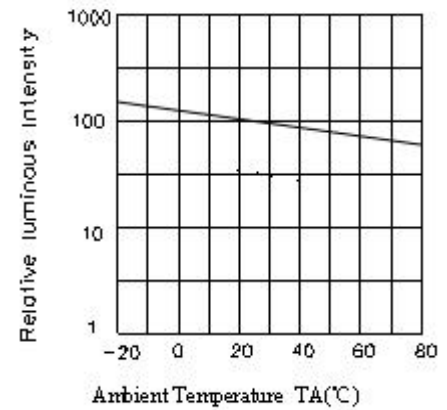
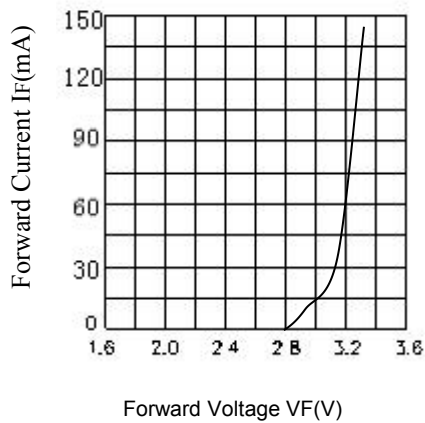
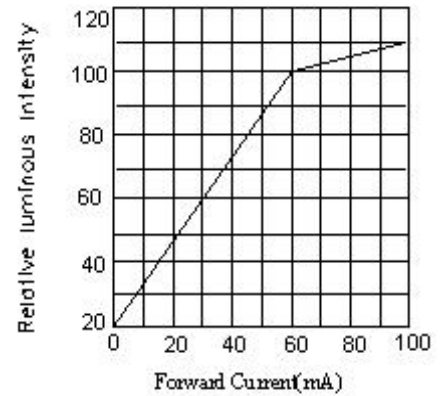
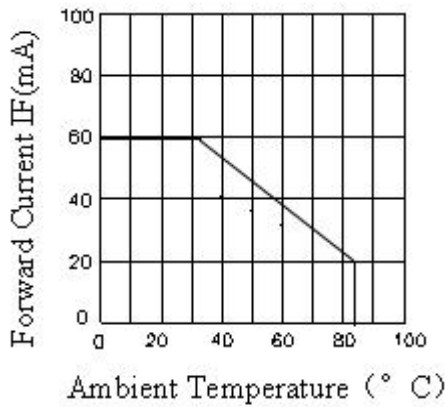

CL-SFC506DWW-3K-90CRI
Bin Color

2800-3100K

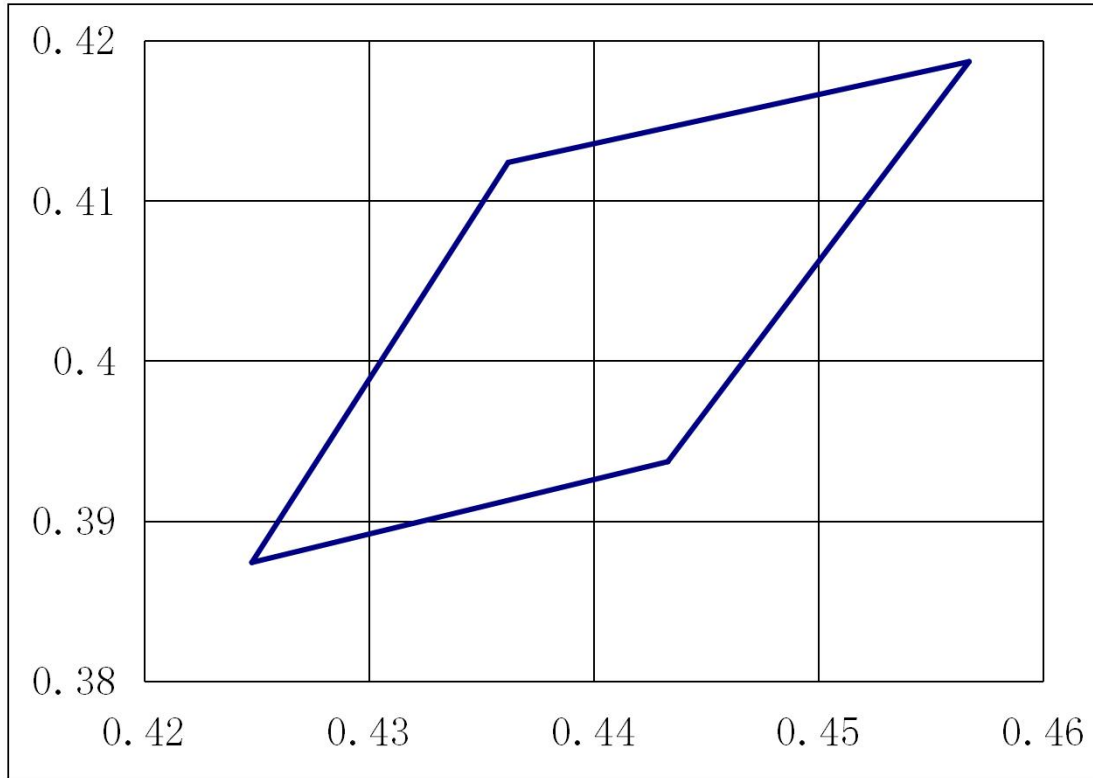

F306 2800-3100K				
x	0.4362	0.4567	0.4433	0.4248
y	0.4124	0.4187	0.3937	0.3874

CL-SFC506DWW-3K-90CRI

Reliability Test Items And Conditions

The reliability of products shall be satisfied with items listed below.

Confidence level :90%

LTPD :10%

Test Items	Test conditions	Quantity	Judging Criteria
Solderability	Solder Temperature: 240°C Solder Duration: (3.5±0.5) sec.	22	Solderable Area Over 95%
Thermal Shock Followed by High Temperature And High Humidity Cyclic	-40° → 10min 5 Cycles ↑ ↓ shift(2~3)min 100°C → 10 min. ☰ 25°C~55°C (90%~95%) RH 2 Cycles for 48 hrs., Recover for 2 hrs	22	C=0 & I**
Resistance For Soldering Heat	Reflow Soldering	22	C=0 & I**
DC Operating Life	1000 hrs. Forward Current: 60mA	22	C=0 & I**
High Temperature Storage	100°C ☐ → 1000 hrs	22	C=0 & I**
High Temperature And High Humidity Cyclic	25°C~55°C (90%~95%) RH 6 Cycles for 144 hrs., Recover for 2 hrs.	22	C=0 & I**

The technical information shown in the data sheets are limited to the typical characteristics and circuit examples of the referenced products. It does not constitute the warranting of industrial property nor the granting of any license.

CL-SFC506DWW-3K-90CRI

SMT Reflow Soldering Instructions

1. Reflow soldering is not can do two times
2. When soldering , do not put stress on the LEDs during heating .

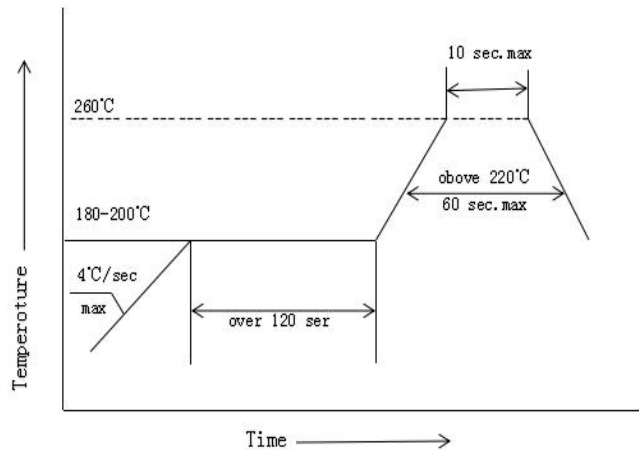

3. Product is highest resistant to 260°C , reflow but suggested the highest temperature of 240°C within .

Soldering iron

1. When hand soldering, the temperature of the iron must less than 300°C for 3 seconds
2. The hand solder should be done only one times

Repairing

Repair should not be done after the LEDs have been soldered. When repairing is unavoidable, a double-head soldering iron should be used (as below figure). It should be confirmed beforehand whether the characteristics of LEDs will or will not be damaged by repairing.

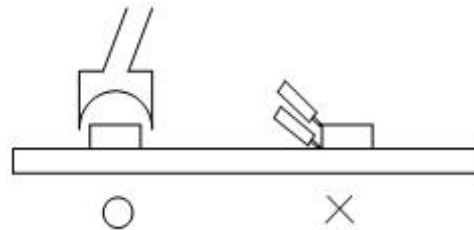

Storage

The package is sealed:

1. The LEDs Should be store at 5°C~30°C and 90% RH or less.
2. It is recommended that SMD out of their original packainq are used within one year.

The package is opened:

1. Completed within 168 hours.
2. Stored at 5°C~30°C and 60% RH or less.
3. LEDs stored more than 168 hours should be baked at about 60°C±5°C for at least 20 hours before solder assembly.

Handling Precautions

1. Do not stack together assembled PCBs containing LEDs. Impact may scratch the silicone lens or damage.

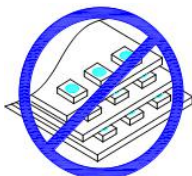

2. Not available in the situation of acidity for PH.



CL-SFC506DWW-3K-90CRI

Carrier tape

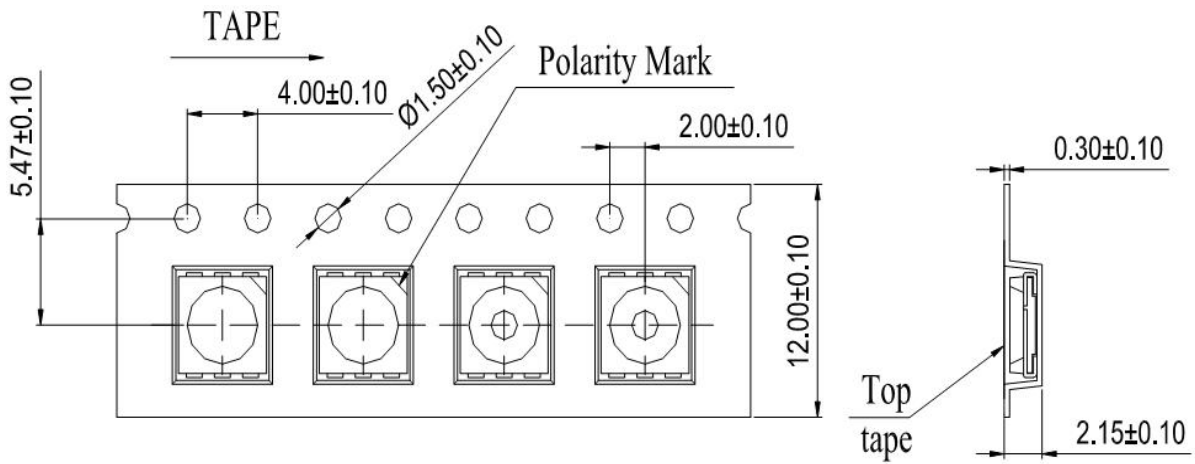

Package: 1000pcs/reel

All dimensions in mm, tolerances unless mentioned is ± 0.1 mm.

Moisture Resistant Packaging

