

# Surface Mounted Chip LED

**SP1606DLG**

◆ Features :

- Compatible with automatic placement equipment
- Compatible with reflow solder process

◆ Applications :

- Automotive\_Telecommunication
- Indicators
- LCD Back-lights
- Illuminations

Dice Material	Light Color	Lens Color
GaN	<b>GREEN</b>	Water Clear

◆ Absolute Maximum Ratings

( Ta=25°C )

Item	Symbol	Maximum	Unit
Power Dissipation	P <sub>D</sub>	135	mW
Continuous Forward Current	I <sub>Fmax</sub>	30	mA
Peak Forward Current (1/10 Duty Cycle 0.1ms Pulse Width)	I <sub>FP</sub>	140	mA
Reverse Voltage	V <sub>R</sub>	5	V
Derating Linear From 25°C		0.4	mA/°C
Operating Temperature Range	Topr	-40 to +85	°C
Storage Temperature Range	Tstg	-40 to +85	°C

◆ Electrical/Optical Characteristics

( Ta=25°C )

Item	Symbol	Condition	Min.	Typ.	Max.	Unit
Forward Voltage	V <sub>F</sub>	I <sub>F</sub> = 5mA				V
		I <sub>F</sub> =20mA	2.7	3.0	3.3	
Reverse Current	I <sub>R</sub>	V <sub>R</sub> =5V			10	uA
Peak Emission Wavelength	λ <sub>P</sub>	I <sub>F</sub> =20mA		525		nm
Dominant Wavelength	λ <sub>D</sub>	I <sub>F</sub> =5mA				nm
		I <sub>F</sub> =20mA	520	525	530	
Viewing Angle	2θ <sub>1/2</sub>	I <sub>F</sub> =20mA		130		Deg
Luminous Intensity	I <sub>V</sub>	I <sub>F</sub> =5mA				mcd
		I <sub>F</sub> =20mA	300	350	500	

※The measuring tolerance → Luminous intensity ±15%  
Wavelength (λ<sub>D</sub>) ±2nm

APPROVER	DIMENSION NO :	VERSION :	DATE :
		A0	2006/03/01
	ISSUE :	CHECKER :	ENGINEER :

◆ Dimensions / Taping and Package Spec.

● Package Dimensions of Device ( SP1606 Series )

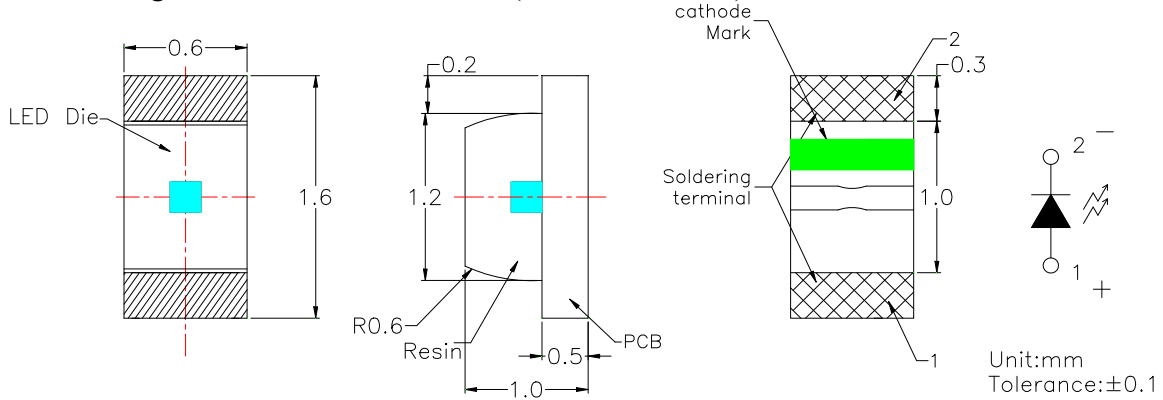

1. Soldering terminal may shift in x, y direction.

● Recommended Soldering Pad Dimensions

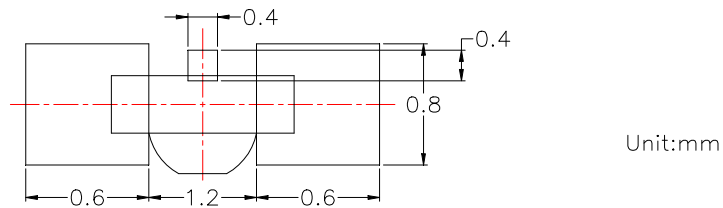

● Tape Specification : 4000pcs Per Reel

Packing Size													
Item	W	P1	E	F	Do	D1	PO	10PO	P2	Ao	Bo	Ko	t
Spec.	8.00	4.00	1.75	3.50	1.50	0.5	4.00	40.00	2.00	1.15	1.8	0.75	0.23
Tolerance	±0.20	±0.10	±0.10	±0.05	$^{+0.10}_{-0.00}$	±0.05	±0.05	±0.20	±0.05	±0.10	±0.10	±0.10	±0.05

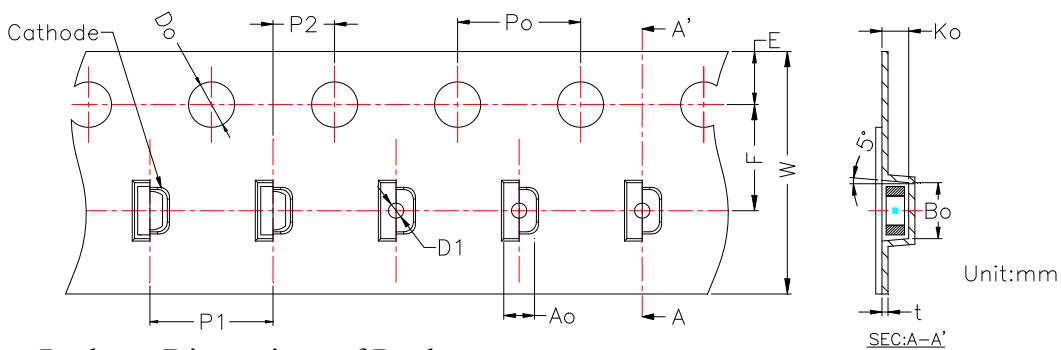

● Package Dimensions of Reel

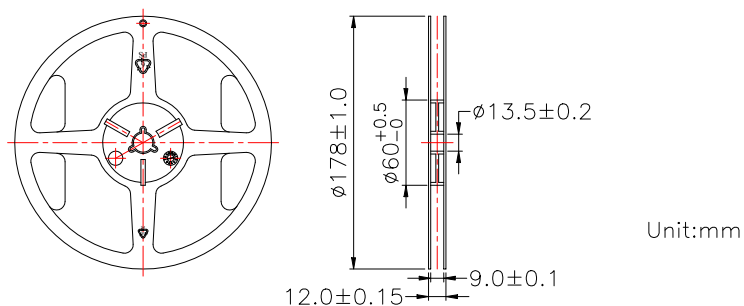

◆ **Typical Electro-Optical Characteristic Curves**  
**Ultra High Brightness Type**

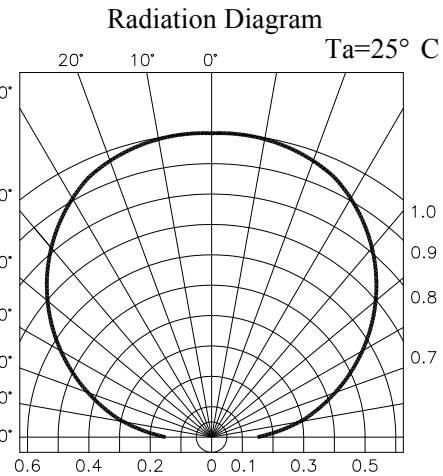
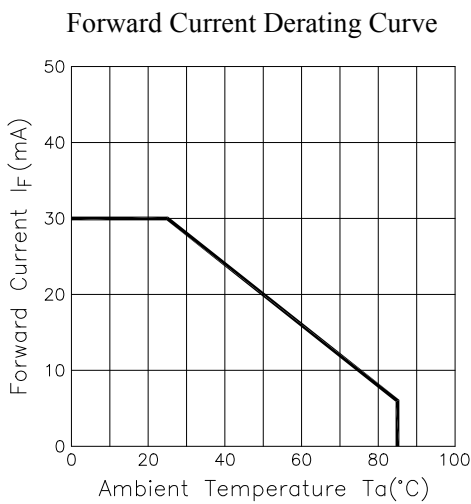
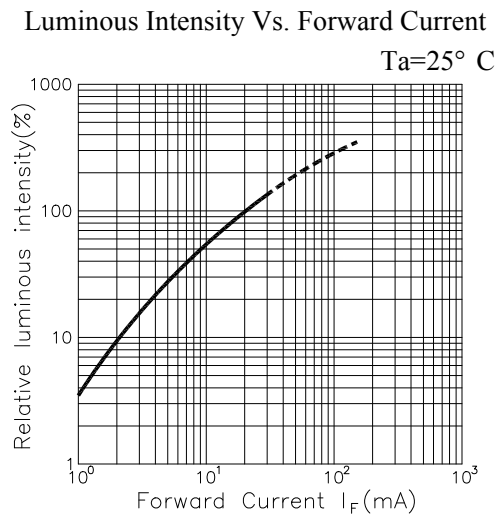
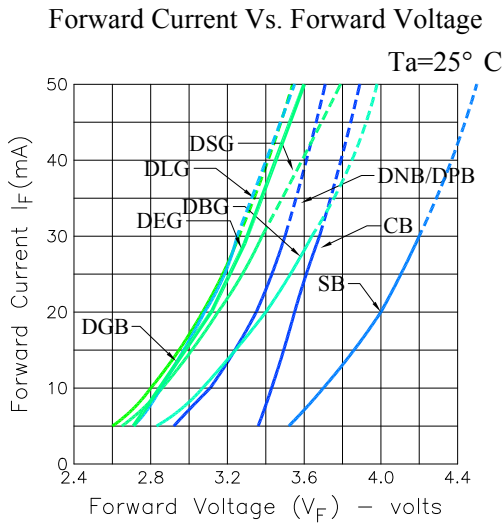

**Spectrum Distribution**

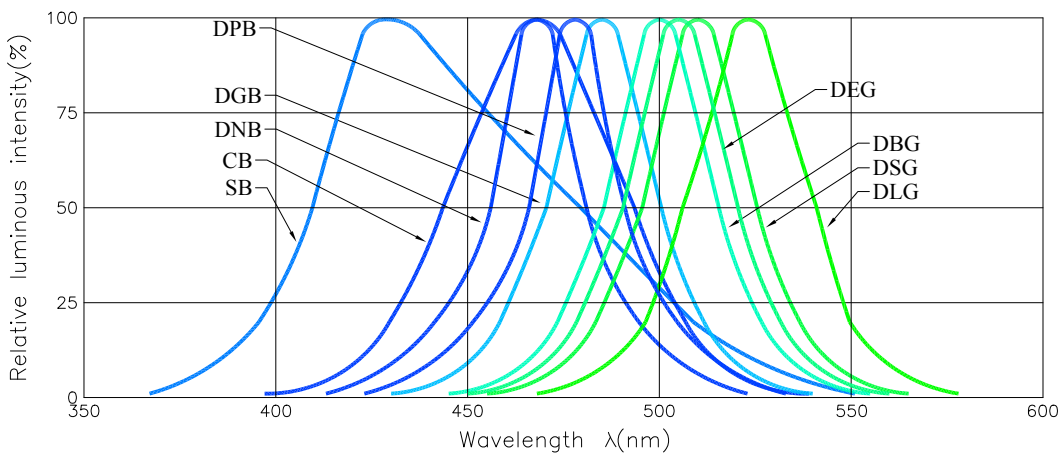

### ◆ Packing and Shipping Instruction

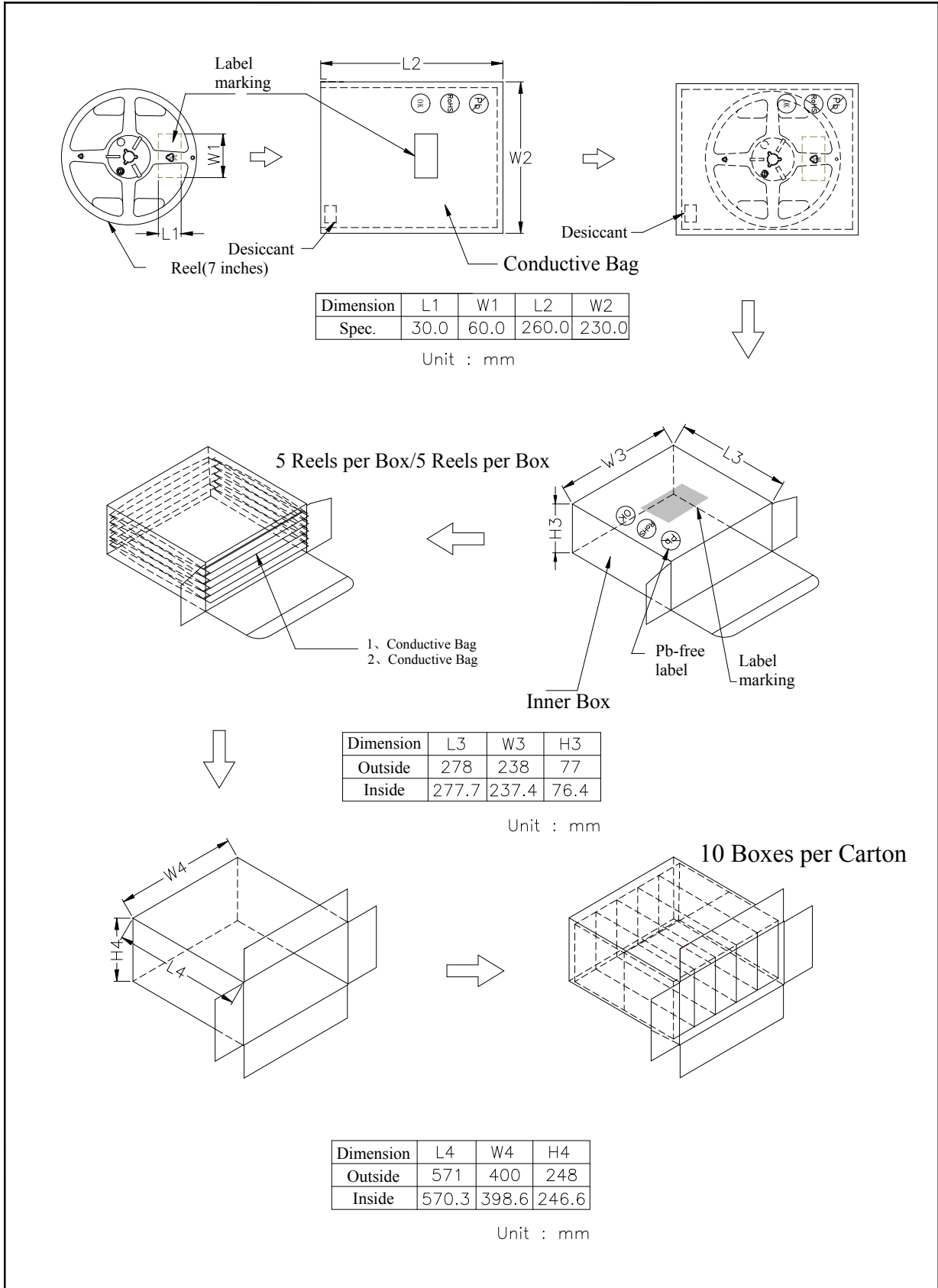

◆ **Descriptions :**

- The Chip-LED Taping is much smaller than lead frame type components, thus enable smaller board size, higher packing density, reduced storage space and finally smaller equipment to be obtained.
- Besides, lightweight makes them ideal for miniature application, etc.

◆ **Reliability Test Items And Conditions :**

No.	Item	Test Conditions	Test hr/cycle/time	Sample Q'ty	Ac / Re
1	Solder Heat	TEMP :260°C±5°C ;10±1 sec	2 times	30 pcs	0 / 1
2	Solderbility Test ※	TEMP :235°C±5°C ;3±1 sec	1 time	5 pcs	0 / 1
3	Temperature Cycle	H : +85°C 30min. ∫ 5min. L : -40°C 30min.	100 cycles	20 pcs	0 / 1
4	Thermal Shock	H : +85°C 5min. ∫ L : -40°C 5min.	50 cycles	20 pcs	0 / 1
5	High Temperature Storage	TEMP : 85°C	1000 hrs	20 pcs	0 / 1
6	Low Temperature Storage	TEMP : -40°C	1000 hrs	20 pcs	0 / 1
7	DC Operating Life	$I_F = I_{Fmax}$	1000 hrs	20 pcs	0 / 1
8	High Temperature High Humidity	85°C / 90~95%R.H.	1000 hrs	20 pcs	0 / 1
9	Shocking test	100~2000Hz ; 98.1m/s <sup>2</sup> X,Y,Z direction	2 hrs	20 pcs	0 / 1
10	Dropping test	Put on pallet ; height : 75cm	3 times	20 pcs	0 / 1
<b>Judgment Criteria</b>					
Forward Voltage $V_F$		$V_F$ Max-Increase < 1.1x			
Reverse Current $I_R$		$I_R$ Max-Increase < $I_{Rmax}$			
Luminous Intensity $I_V$		$I_V$ Decay < 40%			
※Solderbility test criteria : coverage is not less than 95%					
Note : Measurement shall be taken after the tested samples have been returned to normal ambient conditions (generally after two hours)					

◆ **Test Circuit**

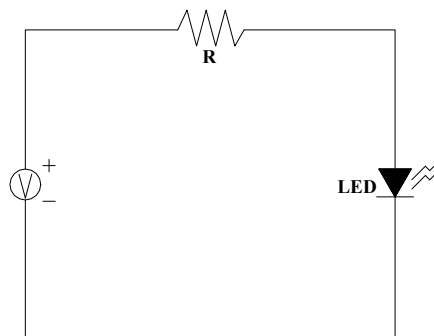

◆ **Precautions For Use :**

- Overdrive current proof  
Customer must apply resistors for protection, otherwise slight voltage shift will cause current change with great deal. ( Burn out will happen )
- Storage
  1. The operation of temperature and R.H. are :  $5^{\circ}\text{C} \sim 30^{\circ}\text{C}$  , 60%R.H. Max..
  2. Once the package is opened, the products should be used within a week. Otherwise, they should be kept in a damp-proof box with desiccant. Considering the tape life, we suggest our customers to use our products within 1.5 year ( from production date ) .
  3. It's recommended to bake before soldering when the package is unsealed more than 72 hrs. The condition is :  $60^{\circ}\text{C} \pm 5^{\circ}\text{C}$  for 15hrs.

◆ **Reflow Temp. / Time :**

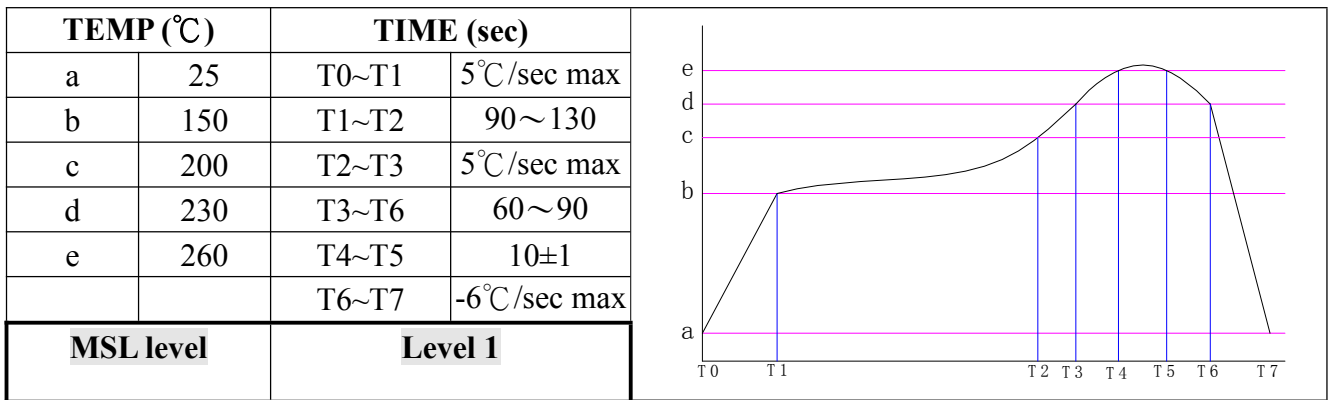

◆ **Hand Soldering Iron :**

- Temperature at tip of iron :  $400^{\circ}\text{C}$  Max. ( 35W Max. )
- Soldering time :  $3 \pm 1\text{sec}$ .

**Model NO : SP1606DLG**

**◆ Luminous Intensity BIN Limits**

Test condition : @20mA		
BIN Code	I <sub>Vmin</sub> (mcd)	I <sub>Vmax</sub> (mcd)
G1	300	350
G2	350	400
G3	400	450
G4	450	500

**◆ Dominant Wavelength BIN Limits**

Test condition : @20mA		
BIN Code	λ <sub>Dmin</sub> (nm)	λ <sub>Dmax</sub> (nm)
1	520	522
2	522	524
3	524	526
4	526	528

**◆ Forward Voltage BIN Limits**

Test condition : @20mA		
BIN Code	V <sub>Fmin</sub> (v)	V <sub>Fmax</sub> (v)
1	2.7	2.8
2	2.8	2.9
3	2.9	3.0
4	3.0	3.1
5	3.1	3.2