

Part no.	SP3806UYG
Emitting color	GREEN YELLOW
Material	AlGaInP
Picture	

■ Absolute Maximum Ratings at (TA=25°C)

Part No.	REVERSE VOLTAGE (<100 uA)	D.C.FORWARD CURRENT	OPERATING TEMPERATURE RANGE	STORAGE TEMPERATURE RANGE	LEAD SOLDERING TEMP.
SP3806UYG	5.0V	30mA	-30°C TO +85°C	-40°C TO +90°C	240 FOR 4 SEC

■ Electrical/Optical Characteristics at TA=25 °C

Part No.	WAVELENGTH Hue @20mA (nm)		FORWARD VOLTAGE @20mA(V)		Reverse Current IR(VR=5V)	LUMINOUS INTENSITY @20mA (mcd)	
	MIN	MAX	MIN	MAX		MIN	MAX
SP3806UYG	570	576	1.8	2.4	10uA	150	400

IV :Tolerance each Binlimit is ±15%

VF: Tolerance each Binlimit is ±15%

■ WAVELENGTH(IF=20mA.Ta=25 °C)

COLOR	GREEN YELLOW	
ITEM	λ d 20mA(nm)	
BIN	MIN	MAX
BIN1	570	571
BIN2	571	572
BIN3	572	573
BIN4	573	574
BIN5	574	575
BIN6	575	576

■ LUMINOUS INTENSITY@20mA(mcd)

COLOR	GREEN YELLOW	
ITEM	IV 20mA(mcd)	
BIN	MIN	MAX
BIN1	150	200
BIN2	200	250
BIN3	250	300
BIN4	300	350
BIN5	350	400

■ FORWARD VOLTAGE@20mA(V)

COLOR	GREEN YELLOW	
ITEM	VF 20mA(V)	
BIN	MIN	MAX
BIN1	1.8	1.9
BIN2	1.9	2.0
BIN3	2.0	2.1
BIN4	2.1	2.2
BIN5	2.2	2.3
BIN6	2.3	2.4

Directivity

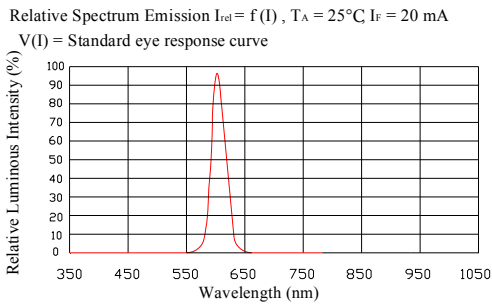

FIG.1 RELATIVE LUMINOUS INTENSITY

Forward Current $I_F = f(V_F)$

$T_A = 25^\circ\text{C}$

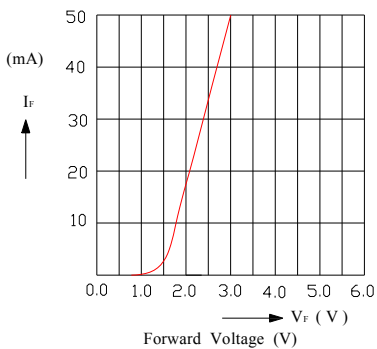

FIG.2 FORWARD CURRENT VS. FORWARD VOLTAGE

Relative Luminous Intensity $I_v/I_v(20\text{mA}) = f(I_F)$

$T_A = 25^\circ\text{C}$

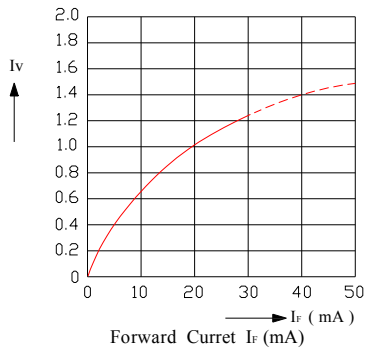

FIG.3 RELATIVE LUMINOUS INTENSITY VS. FORWARD CURRENT

Ambient Temperature VS. Allowable Forward Current

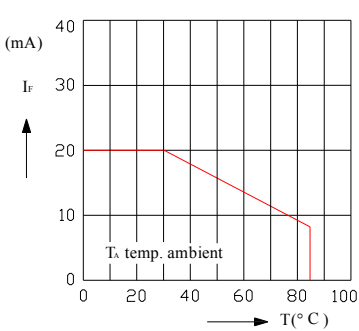

FIG.4 FORWARD CURRENT VS. AMBIENT TEMPERATURE

Radiation Characteristic $I_{rel} = f(\theta)$

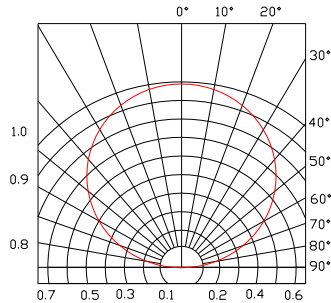
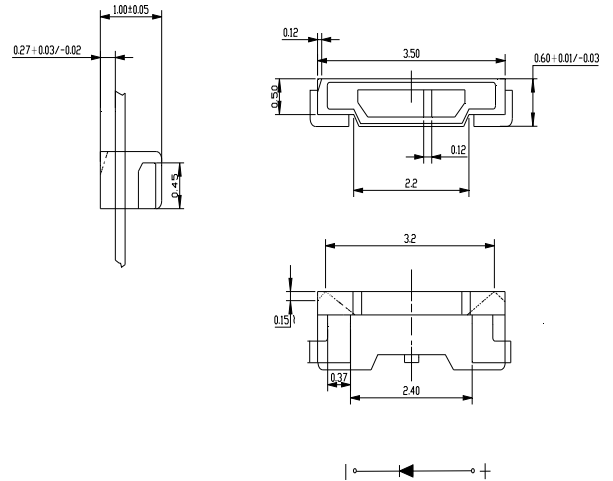
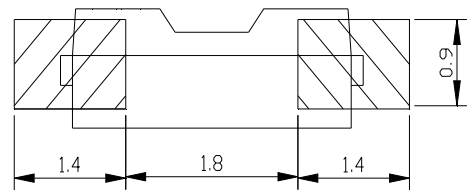

FIG.5 RADIATION DIAGRAM

Dimensions (Unit:mm)



recommended



Package specifications (mm)

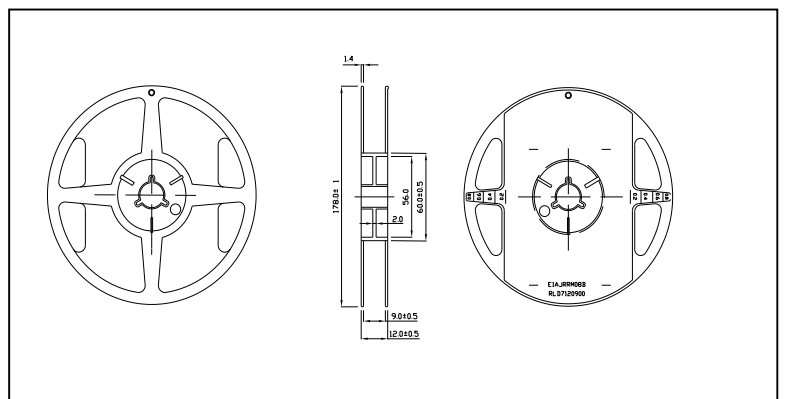
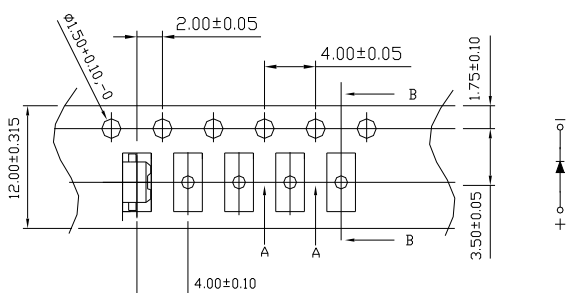

RELIABILITY

TEST ITEMS AND RESULTS				
Test Item		Test Conditions	Note	Number of Damaged
Solderability (Reflow Soldering)	JEITA ED-4701 300-301	Tald=240±5°C 4sec	1 time over 95%	0/50
Thermal Shock	MIL-STD 202-107D MIL-STD 705-1051 MIL-STD 808-1011	0°C - 90°C 15sec. 15sec	20cycles	0/50
Temperature Cycle	JEITA ED-4701 100-105	-40°C - 25°C - 90°C - 25°C 30min. 5min. 30min. 5min	100 cycles	0/50
Moisture Resistance Cyclic	JEITA ED-4701 200-203	25°C - 65°C - -10°C 90%RH 24hrs/1cycle	10 cycles	0/50
Temperature Humidity Storage	MIL-STD202-103B JIS-C-7021 B-11	Ta=60°C RH=90%	1000hrs	0/50
Low Temperature Storage	JIS-C-7021 B-12	Ta=-40°C	1000hrs	0/50
Steady State Operating Life of High Humidity Heat	MIL-STD202-103B JIS-C-7021 B-11	85°C, RH=85%, If=20mA	500hrs	0/50

JUDGMENT CRITERIA OF FAILURE FOR THE RELIABILITY

Measuring items	Symbol	Measuring conditions	Judgement criteria for failure
Forward voltage	VF (V)	IF=20mA	Over U*1.2
Reverse current	IR (uA)	VR=5V	Over U*2
Luminous intensity	IV (mcd)	IF=20mA	Below S*0.5

Note: 1.U means the upper limit of specified characteristics. S means initial value.

2. Measurement shall be taken between 2 hours and after the test pieces have been returned to normal ambient conditions after completion of each test.

LED

Application (Soldering)

Manual soldering (We do not recommend this method strongly.)

Soldering tin material: tin 6/4 alloy or contained Ag.

To prevent cracking, please bake before manual soldering.

keep the temperature on the edge of iron at 300 °C Max. (25W) and apply for 3 seconds. If the temperature become higher, apply in a shorter time (1sec)

In manual soldering, take care not to damage the package especially terminal or resin.

(Do not give stress to the product when soldering.)

Do not use again if you remove the soldeGREEN YELLOW product.

It is recommended using an iron with a temperature control.

Reflow Soldering

Recommend tin glue specifications:

Melting temperature: 150-260°C

Contains: Sn 96.5%, Ag 3.0%, Cu 0.5% JIS Z 3282 TEST

Never take next process until the component is cooled down to room temperature after reflow.

The recommended reflow soldering profile (measuring on the surface of the LED resin) is following:

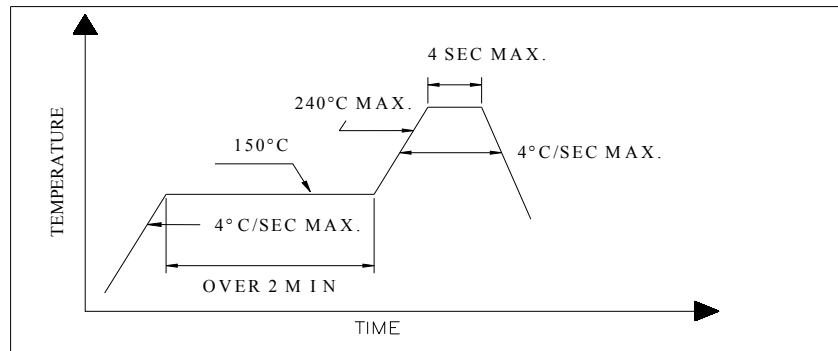

Cleaning

The conditions of cleaning after soldering:

An alcohol-based solvent such as Isopropyl Alcohol (IPA) is recommended.

Temperature Time: <50°C*30sec, or <30°C*3min

Ultra sonic cleaning: <15W/bath; Bath volume: 1liter max.

Curing: 100 max, <3min

Cautions of Pick and Place

It should be avoided to load stress on the resin during high temperature.

Avoid rubbing or scraping the resin by any object.

Electric-static may cause damage to the component. Please confirm that the equipment is grounding well. Using an ionzer fan is recommended.

Cautions of Design and Applications

It should be done to connect with a current-limiting serial resistor. Avoid to drive reverse voltage over the specifications on LED when ON/OFF.

Any application should refer to the specifications of absolute maximum ratings.

The dimensions of the recommended soldering pattern may not meet every user. Please confirm and study first before designing the soldering pattern in order to obtain the best performance of soldering.

Do not contact with any component on the assembly board.

Appendix

Notes for designing

Care must be taken to provide the current limiting resistor in the circuit so as to drive the Ju Yuan LEDs within the rated figures. Also, caution should be taken not to overload Ju Yuan LEDs with instantaneous voltage at the turning ON and OFF of the circuit.

When using the pulse drive care must be taken to keep the average current within the rated figures. Also, the circuit should be designed so as to be subjected to reverse voltage when turning off the Ju Yuan LEDs.

Storage

In order to avoid the absorption of moisture, it is recommended to solder Ju Yuan LEDs as soon as possible after unpacking the sealed envelope.

If the envelope is still packed, to store it in the environment as following

- (1) Temperature: 5°C -30°C (41° F) Humidity: RH 60% Max.
- (2) After this bag is opened, devices that will be applied to infraGREEN YELLOW reflow, vapor-phase reflow, or equivalent soldering process must be:
 - a. Completed within 24 hours.
 - b. StoGREEN YELLOW at less than 30% RH.
- (3) Devices require baking before mounting, if:
 - (2) a or (2) b is not met.
- (4) If baking is required for GREEN YELLOW, devices must be baked under below conditions:
48 hours at 70°C \pm 3°C .