

## 1. Features

- ▶ Very highly efficient GaAs Chip.
- ▶ High reliability.
- ▶ High pulse handling capability.
- ▶ Good spectral match to silicon photo detectors.

## 2. Applications

- ▶ IR remote control for HIFI and TV sets, video tape recorders, dimmers.
- ▶ Light-reflection switches(max.500kHz).
- ▶ Coin counters. Sensor technology.
- ▶ Discrete opto couplers.

## 3. Package Dimensions

Unit : mm

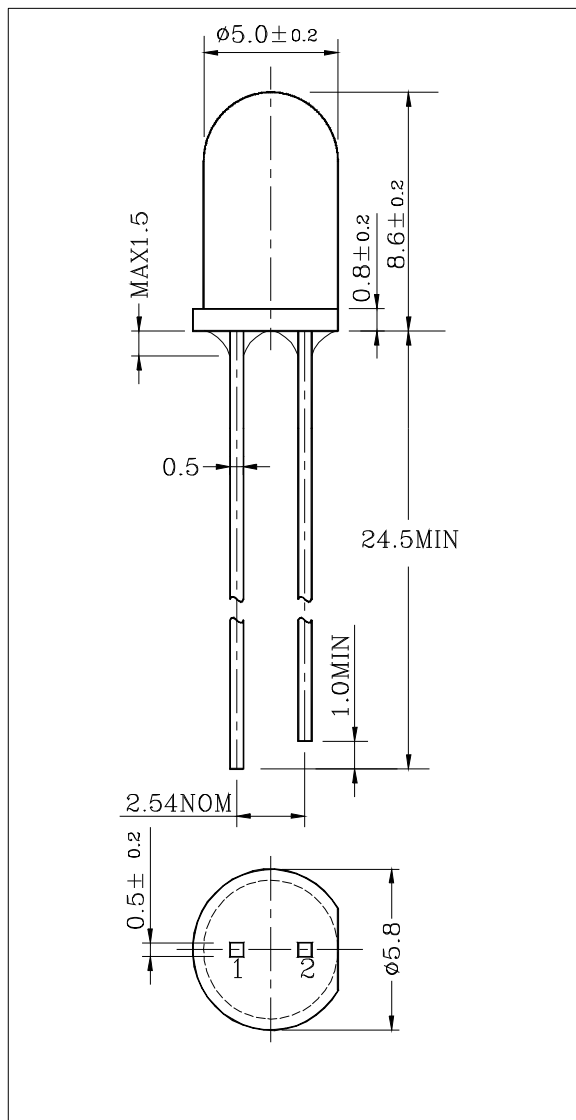

**CL85I5315-C**

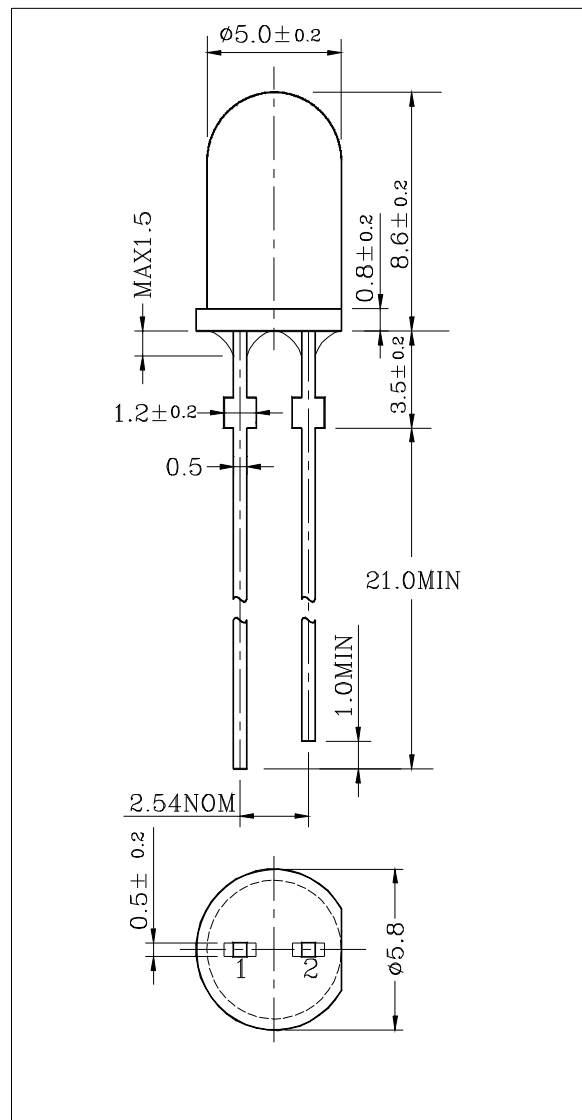

**CL85I5315-C (B) PIN Connections**

1. Anode
2. Cathode

**4. Absolute maximum ratings**

Ta=25°C

Item	Symbol	Ratings	Unit
Forward Current	$I_F$	100	mA
Pulse Forward Current *1	$I_{FP}$	1	A
Power Dissipation	$P_D$	190	mW
Reverse Voltage	$V_R$	5	V
Operating Temperature	$T_{opr}$	-30~85	°C
Storage Temperature	$T_{stg}$	-30~100	°C
Soldering Temperature *2	$T_{sol}$	260±5°C	°C

\*1. Pulse Width=0.1msec, Duty ratio = 1/16

\*2. 5 sec at location 2.0mm away from the base of the epoxy bulb.

**5. Electrical Characteristics**

Ta=25°C

Item	Symbol		Test Condition	Min	Typ	Max	Unit
Forward Voltage	$V_F$		$I_F= 50\text{mA}$	-	1.5	1.8	V
Reverse Current	$I_R$		$V_R=5[V]$	-	-	10	μA
Radiant Intensity *3	$I_E$	G	$I_F= 50\text{mA}$	80	-	110	mW/ sr
		H		110	-	150	
		I		150	-	210	
Peak Wavelength	$\lambda_P$		$I_F= 50\text{mA}$	-	850	-	nm
Spectrum Radiation Band width	$\Delta\lambda$		$I_F= 50\text{mA}$	-	42	-	nm
Viewing Angle	2θ1/2		$I_F= 50\text{mA}$	-	±20	-	deg

\*3. This Value includes ±20% tolerance caused by Luminous Intensity measurement method of Ciel Light Co.LTD

## 6.Characteristic Diagrams (typical)

**Fig.1  $I_F - V_F$**

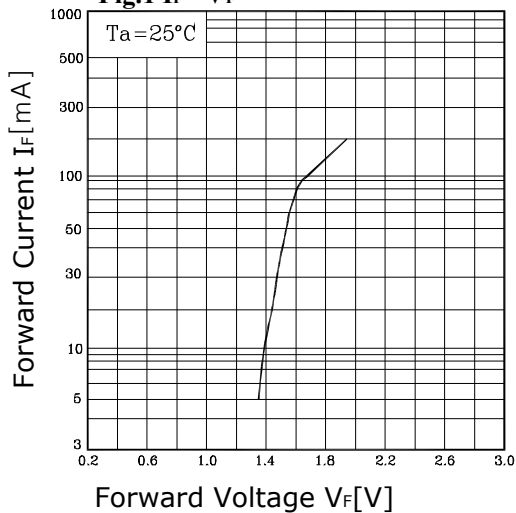

**Fig.2  $I_F - T_a$**

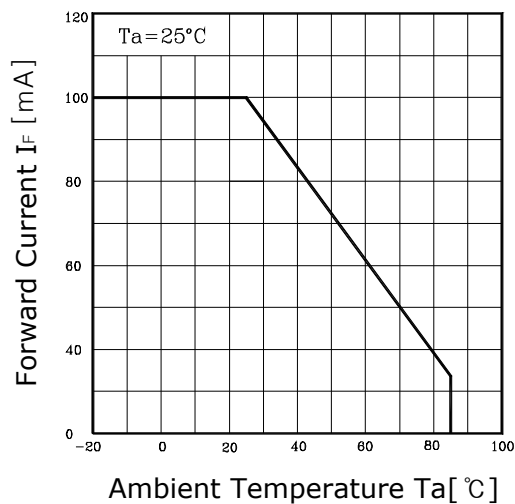

**Fig.3 Spectrum Distribution**

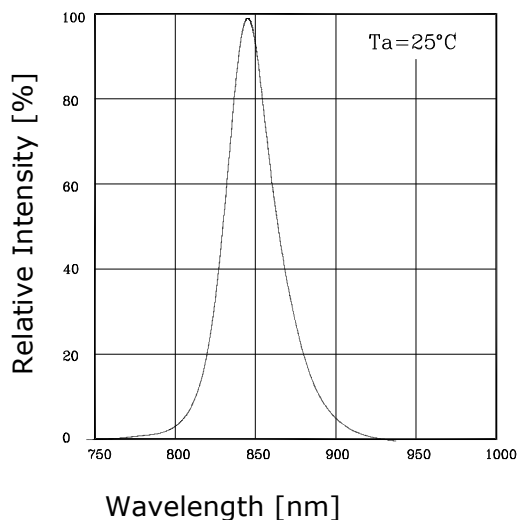

**Fig.4  $I_e - I_F$**

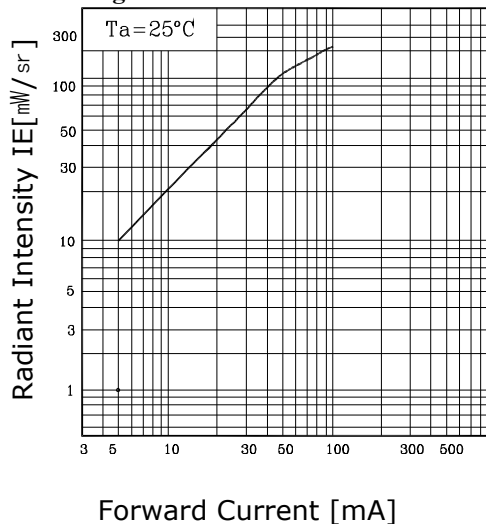

**Fig.5 Radiation Characteristics**

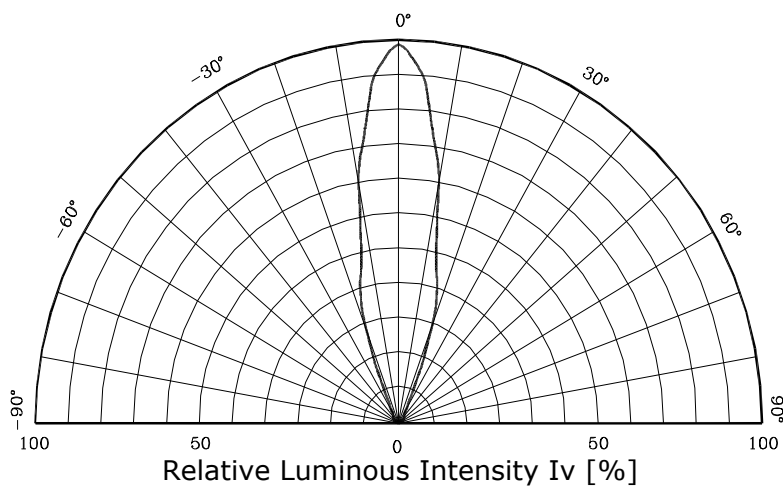

## 7-1. Reflow Soldering

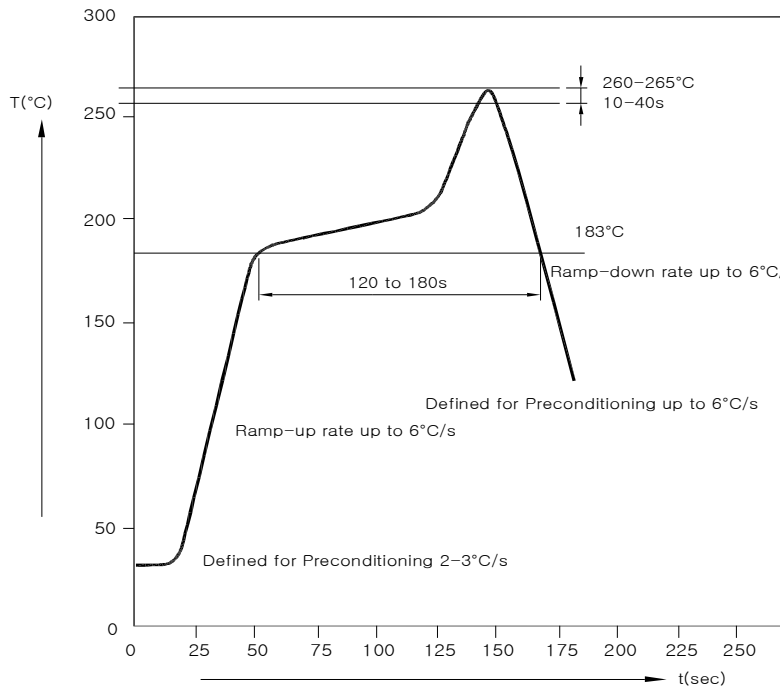

## 7-2. TTW Soldering

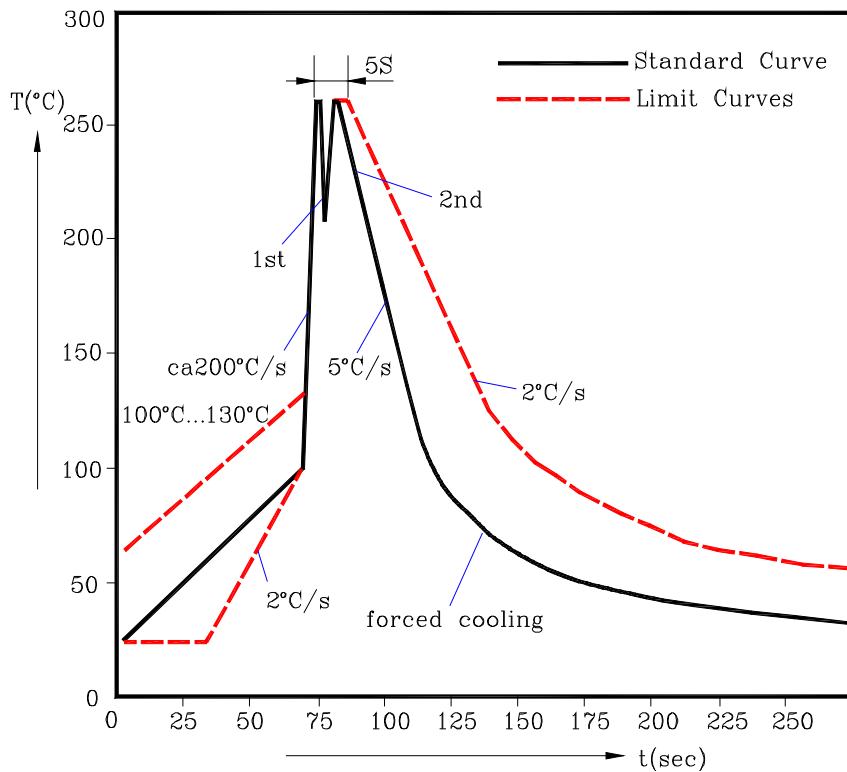

## 8. Reliability Test Items and Conditions

### 8-1. The Reliability criteria of LED Lamps

Item	Symbol	Test Condition	Limit	
			Min	Max
Forward Voltage	V <sub>F</sub>	I <sub>F</sub> =50mA	-	U.S.L × 0.7
Reverse Current	I <sub>R</sub>	V <sub>R</sub> =5V	-	U.S.L × 0.7
Luminous Intensity	I <sub>V</sub>	I <sub>F</sub> =50mA	L.S.L × 0.7	-

※ U.S.L. : Upper Standard Level

※ L.S.L. : Lower Standard Level

### 8-2. Results of Reliability Test

No	Item	Test Condition	Test Hours/ Cycles	Sample Size	Ac/Re
1	Solder Heat	Temp : 260°C ± 5°C	5 sec	22 PCS	0 / 1
2	Temperature Cycle	H : +100°C 30min 23°C 5min L : -40°C 30min	100 cycle	22 PCS	0 / 1
3	Thermal Shock	H : +100°C 5min 23°C 10sec L : -40°C 5min	100 cycle	22 PCS	0 / 1
4	High Temperature Storage	Temp : 85°C	1000 HRS	22 PCS	0 / 1
5	Low Temperature Storage	Temp : -30°C	1000 HRS	22 PCS	0 / 1
6	Life Test	T <sub>a</sub> =RT, I <sub>F</sub> =20mA	1000 HRS	22 PCS	0 / 1
7	High Temperature/ High Humidity	T <sub>a</sub> =85°C / RH=85%	1000 HRS	22 PCS	0 / 1

---

**9. Caution on usage**

- 9-1. Static electricity and surge will damage the LEDs. It is recommended to take measures to prevent ESD problem (for example, grounding equipment and the human body, using grounded soldering iron and so on).
- 9-2. Be careful never to exceed, even momentarily, the absolute maximum ratings specified in the data sheet.
- 9-3. Ciel Light will not be held responsible for any damage to the user that may result from accidents or any other reasons during operation of the user's unit if use to exceed the absolute maximum ratings, or not keep the matters that demand special attention.
- 9-4. Store and use where there is no corrosive gas.

**10. Warranty period : One year after delivery.**

---